

## Excel 10 W7751H Smart VAV Actuator

### INSTALLATION INSTRUCTIONS

#### BEFORE INSTALLATION

The W7751H Smart VAV Actuator is a factory-combined Excel 10 Variable Air Volume (VAV) Box Controller and an ML6161B Direct-Coupled Actuator with De-clutch mechanism. The actuator/controller assembly is field mounted to the VAV box damper shaft similar to the mounting of a standard actuator, and the controller wiring is terminated to the screw terminals that are located under a snap-on cover. See Fig. . The Smart VAV Actuator is a Free Topology Transceiver (FTT) LONMARK® compliant controller. The W7751H2025 is for smoke control use.

The ML6161B Direct-Coupled Actuator with De-clutch mechanism (see Fig. 2 for location) allows the installer to manually open or close the VAV box damper connected to the W7751H without power or software tool to command it.

The controller in the W7751H contains a Microbridge flow-through pressure sensor and communicates via the 78 kilobaud Echelon® LONWORKS® Bus Network.

Triac output loads must draw a minimum current of 25 mA at 24 Vac, 60 Hz nominal. Triac maximum current rating: 77mA.

The actuator on the W7751H mounts directly onto the VAV box damper shaft and has up to 70 lb-in. torque (8 Nm), 90 degree stroke, and 90 second timing at 60 Hz.

The actuator on the W7751H can accommodate the optional field-installed auxiliary switches.

NOTE: Mounting thermostat/sensor greater than 20 ft from the W7751H2025 requires 14506944-001 Transient Protectors. They must be installed on the thermostat/sensor leads from the T7770C pins 3, 4, 5, 6, and 7.

#### INSTALLATION

Mount the W7751H on the damper shaft (horizontal only) and allow clearance for wiring, servicing and module removal. Avoid mounting the W7751H in areas where acid fumes or other deteriorating vapors can attack the metal parts of the actuator, or in areas where escaping gas or other explosive vapors are present. See Fig. 2 for mounting dimensions

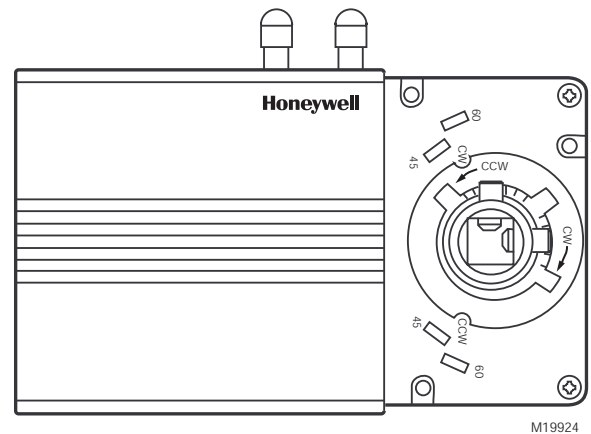

Fig. 1. Excel 10 Smart VAV Actuator.

#### IMPORTANT

*The assembly is intended only for horizontal shaft mounting to assure proper heat dissipation from the controller housing. The Smart VAV Actuator must not be mounted with the controller at the top.*



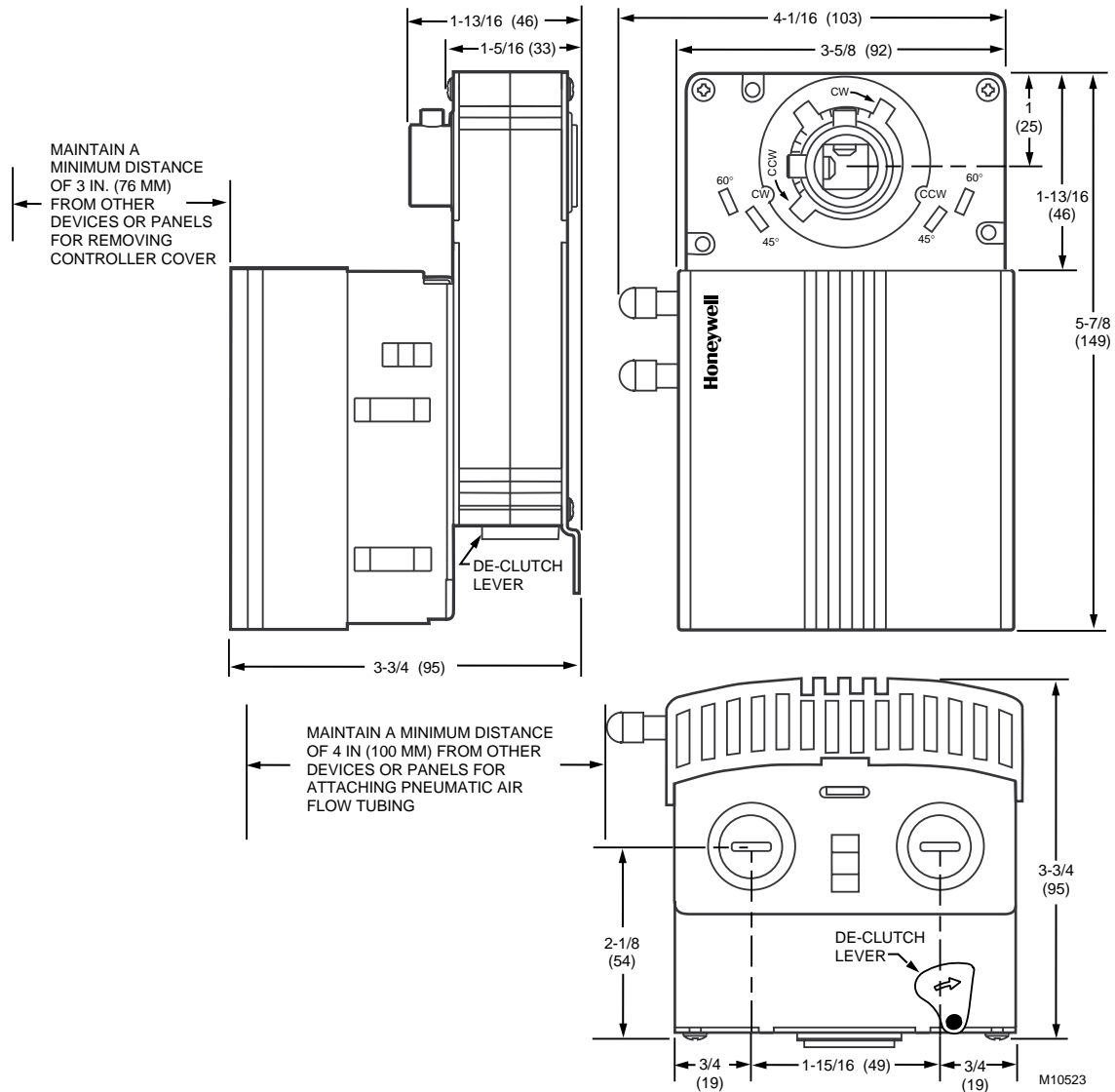

Fig. 2. W7751H mounting dimensions in in. (mm).

The W7751H assembly is field mounted to the VAV box damper shaft, the same as used for a typical actuator. The actuator on the W7751H opens or closes a damper by driving the damper shaft in either the counterclockwise (CCW) or clockwise (CW) direction. The actuator has a mounting tab on the bottom for securing to a VAV box damper. The mounting tab is accessible through a hole in the controller with its cover removed (see Fig. 3). The tab is sized for a 1/4 in. (6 mm) screw or pin (not included).

The controller enclosure on the W7751H is constructed of a sheet metal housing and a plastic snap-on cover. Controller wiring on the W7751H is terminated to screw terminal blocks located under the snap-on cover. See Wiring section. The sheet metal housing has two 1/2 inch (13 mm) knockouts (see Fig. 2) compatible with 1/2 inch (13 mm) or 3/4 inch (19 mm) conduit.

NOTE: The assembly is intended only for mounting to a horizontal shaft.

The W7751H actuator is shipped in the fully clockwise (CW) position (90 degree). The W7751H Assembly must be mounted to a horizontal damper shaft to assure proper heat dissipation from the controller housing. Mount the W7751H so that the actuator is parallel with the VAV box damper housing. In general, it is recommended that a washer or spacer be added between the VAV box damper housing and the actuator mounting tab to keep them parallel. See Fig. 4.



## CAUTION

**Equipment Damage Hazard.**  
**Mounting actuator unevenly with damper housing can damage actuator.**

Mount actuator flush with damper housing or add spacer between mounting tab and damper box housing. (See Fig. 4.)

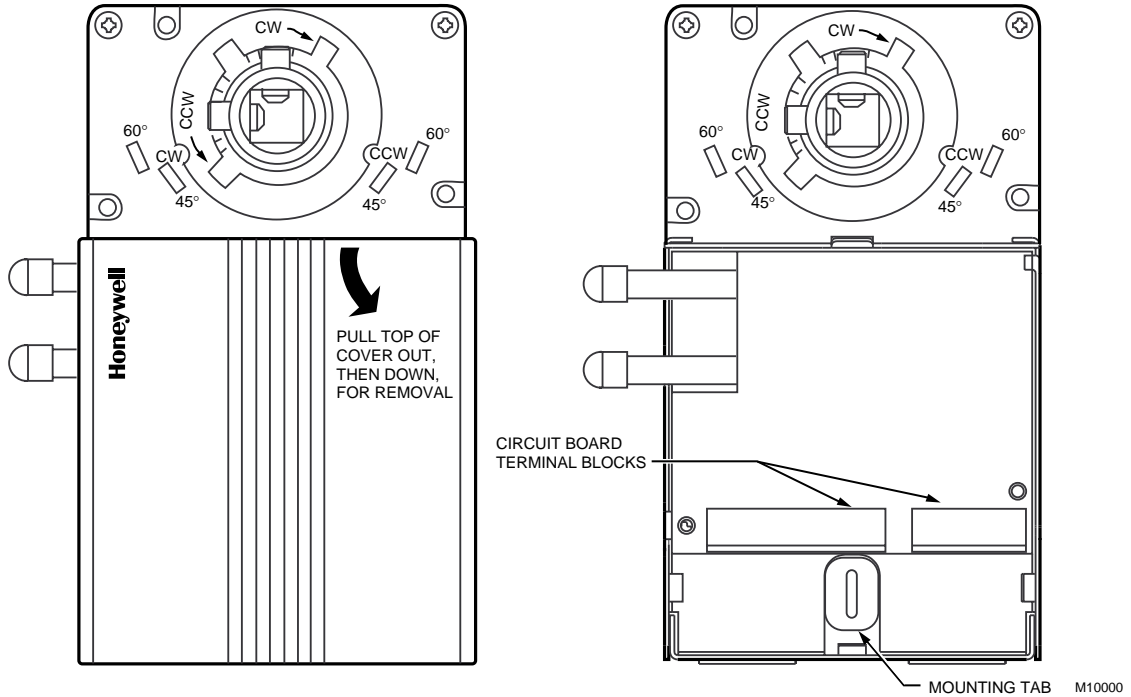

Fig. 3. Cover removal and mounting tab/terminal block access.

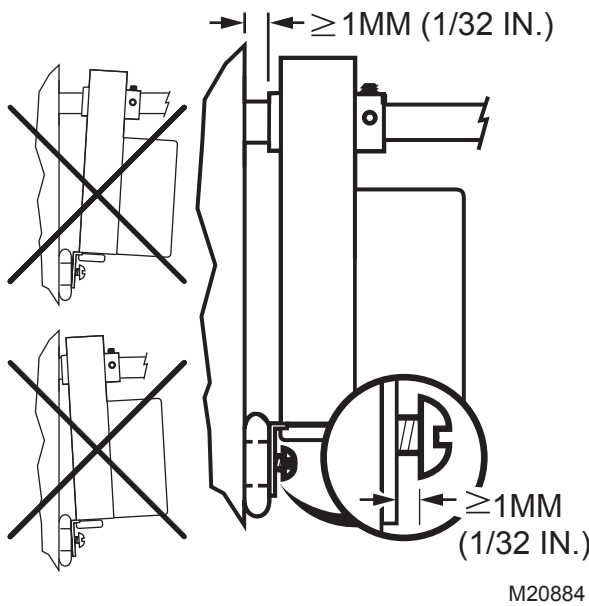

Fig. 4. Mounting W7751H to VAV box damper housing when actuator is not parallel to VAV box damper housing.

Before mounting the W7751H onto the VAV box damper shaft, determine the following:

1. The damper shaft diameter, 3/8 to 1/2 in. (10 to 13 mm).
2. If the length of the VAV box damper shaft is less than 1-3/8 in. (35 mm), use the Short Shaft Adapter Kit (not included), part no. 4074EVK.

3. The direction the damper shaft rotates to open the damper (CW or CCW), see Fig. 5.
4. The damper opening angle (45, 60, or 90 degrees).

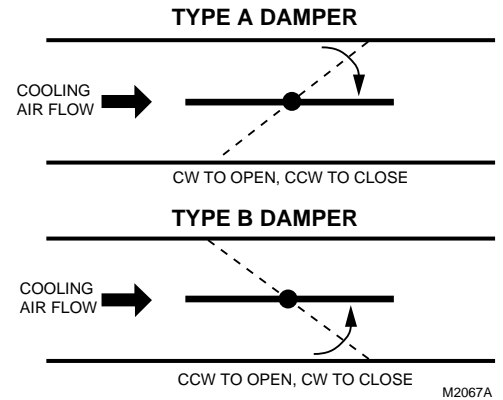
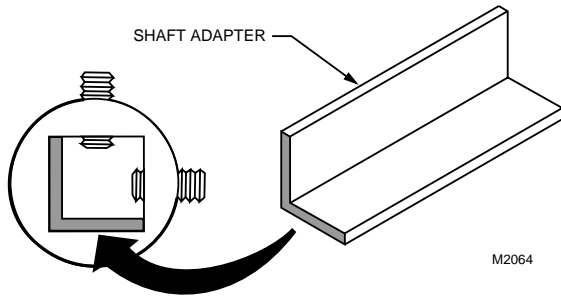

Fig. 5. Determining rotation direction (CW or CCW) for damper opening.

If damper shaft diameter is 3/8 inch (10 mm) round or square, use part 201391 Shaft Adapter (shipped with the W7751H Smart VAV Actuator). Ensure it is placed opposite set screws. See Fig. 6. The adapter centers a 3/8 in. (10 mm) shaft in the hub. Failure to use the adapter on a 3/8 in. (10 mm) shaft causes the mounting tab to loosen. A 1/2 in. (13 mm) shaft does not require the use of the adapter.



**Fig. 6. Use Damper Shaft Adapter for 3/8 in. (10 mm) diameter round or square damper shafts.**

The W7751H is shipped with the actuator rotated in the fully clockwise (CW) position. The installation procedure varies depending on the damper direction and angle:

1. If the damper rotates clockwise (CW) to open, and the angle of the damper open to closed is 90 degrees, manually open the damper fully to the clockwise direction and mount the W7751H to the VAV damper box and shaft. Tighten the Allen set screws. The part no. 201614 Range Stop Pin, which is shipped with the W7751H Smart VAV Actuator, is unnecessary. When the W7751H closes, the damper rotates CCW 90 degrees to fully close.
2. If the damper rotates clockwise (CW) to open, and the angle of the damper open to closed is 45 or 60 degrees, manually open the damper fully to the clockwise direction and mount the W7751H to the VAV damper box and shaft. Tighten the Allen set screws. Insert the part no. 201614 Range Stop Pin, which is shipped with the W7751H Smart VAV Actuator, in either the 45 or 60 degree CCW slot, whichever applies (see Fig. 7). The range stop pin must go all the way through the housing. The pin can only be installed in the CCW slots when the actuator is in the CW position. When the W7751H closes, the damper rotates CCW either 45 or 60 degrees to fully close.
3. If the damper rotates counterclockwise (CCW) to open, and the angle of the damper open to closed is 90 degrees, manually close the damper fully to the clockwise direction and mount the W7751H to the damper box and shaft. Tighten the Allen set screws. The part no. 201614 Range Stop Pin, which is shipped with the W7751H Smart VAV Actuator, is unnecessary. When the W7751H opens, the damper rotates CCW 90 degrees to fully open.

**NOTE:** Be aware that the damper is closed. Until the W7751H is powered and the damper is driven open, starting the fan system with all the VAV box dampers closed can cause duct over-pressurization and damage.

4. If the damper rotates counterclockwise (CCW) to open, and the angle of the damper open to closed is 45 or 60 degrees, see the following NOTE.

**NOTE:** Special precautions must be taken for this application. Mount the W7751H to the damper box. (Do not tighten the Allen set screws yet). Before the part no. 201614 Range Stop Pin, which is shipped with the W7751H Smart VAV Actuator, can be inserted in either the 45 or 60

degree CW slot, the damper actuator must be driven fully open (CCW). To do this, the controller on the W7751H must be wired, powered, and connected to the portable PC via the Serial LonTalk® Adapter (SLTA). The SLTA connects to the controller on the W7751H via the jack for Network Access on T7770 Wall Module or by the B-Port on the Q7750A Zone Manager. From E-Vision Software, drive the actuator on the W7751H fully CCW, and insert the range stop pin in either the 45 or 60 degree CW slot, whichever applies (see Fig. 7). The range stop pin must go all the way through the housing. The pin can only be installed in the CW slots when the actuator is in the CCW position. (Disconnect the portable PC once programming has been completed.) Manually open the damper shaft fully (CCW) and then tighten the Allen set screws. When the W7751H closes, the damper will rotate CW 45 or 60 degrees to fully close.

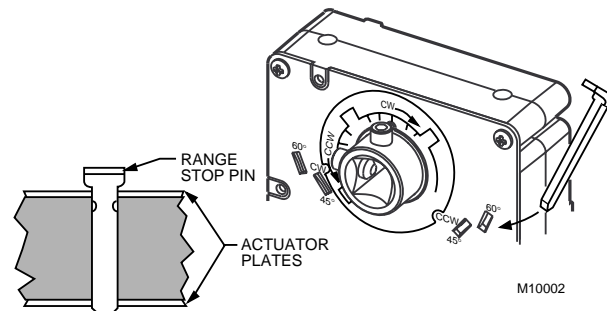

**Fig. 7. Properly inserting range stop pin.**

The Honeywell Software Tool's (miscellaneous parameter for rotation direction) defaults to CW to Open, which applies to the damper direction and angle in items 1 and 2 above. The parameter must be changed to CCW to Open if the damper shaft rotates in this direction, which applies to the damper direction and angle in items 3 and 4 above.

**IMPORTANT**

*It is advisable to leave the dampers in an open position after W7751H installation to avoid the possibility of overpressurizing the ductwork on fan startup. Use the De-clutch lever (see Fig. 2 for De-clutch lever location) to open the box damper on W7751H controllers that are powered down, to prevent overpressurization in the ductwork on fan startup. To use the De-clutch lever, press and hold the lever in the direction of the arrow (this disengages the motor). Turn the damper shaft until the damper is open and release the lever. When power is restored to the W7751H controller, the controller synchronizes the damper actuator so that the damper is in the correct position upon startup.*

When a range stop pin is used with a field-added auxiliary switch, the tab on top of the range stop pin must point inward toward the VAV damper box shaft. See Fig. 11. This allows clearance for the auxiliary switch housing. To remove the pin, pry it up with a flathead screwdriver. See Fig. 8.

**IMPORTANT**

The minimum position set screw on the actuator is not available on the W7751H device.

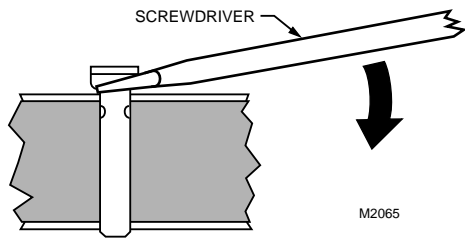

Fig. 8. Lifting a range stop pin out of its slot.

**Piping**

**Air flow Pickup**

Connect the air flow pickup to the two connectors on the controller of the W7751H. See Fig. 9.

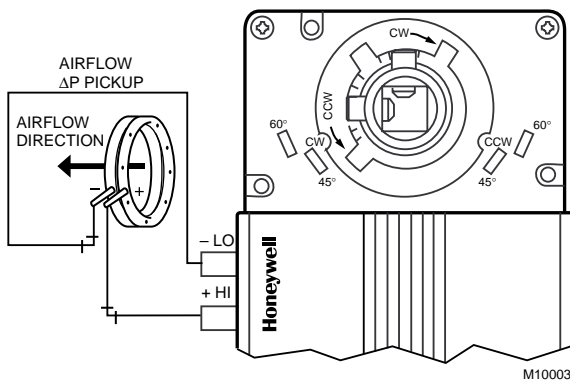

Fig. 9. Smart VAV Actuator air flow pickup connections.

NOTES:

- Use 1/4 in. (6 mm) outside diameter with 0.040 in. (1 mm) wall thickness plenum rated 1219 FR (94V-2) pneumatic tubing.
- Always use a fresh cut on the end of the tubing that connects to the air flow pickups and the connectors on the VAV controllers.

Connect the high pressure or upstream tube to the plastic restrictor labeled (+ HI) or P1 and the low pressure or downstream tube to the restrictor labeled (- LO) or P2. See labeling in Fig. 9.

NOTES:

- If controllers are mounted in unusually dusty or dirty environments, a 5-micron disposable air filter is recommended for the high pressure line (marked as +) connected to the air flow pickup.
- When using twin tubing from pickup, split pickup tubing a short length to accommodate connections.
- Tubing from air flow pickup to VAV controller should not exceed three feet (0.914m). Lengths longer than this can degrade flow sensing accuracy.

- To prevent VAV air flow connector breakage, use caution when removing tubing from it. Always pull straight away from connector; never remove by pulling at an angle.

**Wiring**

All wiring must comply with applicable electrical codes and ordinances, or as specified on installation wiring diagrams.

NOTES:

- For multiple controllers operating from a single transformer, the same side of the transformer secondary must be connected to the same input terminal in each controller and the ground terminals (3 on the W7751H, 28 on the W7751B, and 32 on the W7751D,F) must be connected to a verified earth ground for each controller in the group. See Fig. 10. (Controller configurations are not necessarily limited to three devices, but the total power draw including accessories cannot exceed 100 VA when powered by the same transformer. See System Engineering form 74-2949 for power wiring recommendations.)
- All loads on an Excel 10 Controller must be powered by a single transformer.
- Keep the earth ground connection (terminal 3) wire run as short as possible. Refer to Fig. 16.
- Do *not* connect the analog ground terminal (5) to earth ground. Refer to Fig. 16.

**Power**

The 24 Vac power from an energy limited Class II Power Source must be provided to each Smart VAV Actuator. To conform to Class II restrictions, transformers must not be larger than 100 VA. The maximum current draw at 24 Vac is 1.25A.

**IMPORTANT**

- Power must be off prior to connecting to or removing connections from output terminals 9 and 10.
- Use the heaviest gauge wire available, up to 14 AWG (2.0 mm<sup>2</sup>) with a minimum of 18 AWG (1.0 mm<sup>2</sup>), for all power and earth ground wiring. For nonplenum, open areas, run cables exposed (or in conduit, if required).
- If the W7751H Smart VAV Actuator is used on **Heating and Cooling Equipment (UL 1995, US only)** and the transformer primary power is more than 150 volts, connect the transformer secondary to earth ground, see Fig. 10.

NOTE: Maintain a three-inch (76 millimeter) separation between Triac outputs and LONWORKS® Bus wiring throughout installation.

**Auxiliary Switches**

The 201052A,B,C Auxiliary Switch can be used with the W7751H. It allows for control of equipment external to the actuator (for example, electric reheat coils or fan) at an adjustable point in the stroke (from 0 to 90 degrees) of the actuator. The 201052 Switch is field-added. Self-tapping Phillips head screws are included with the switch. The switch can be mounted only one way (see Fig. 11) with the switch contacts pointed to the top of the actuator.

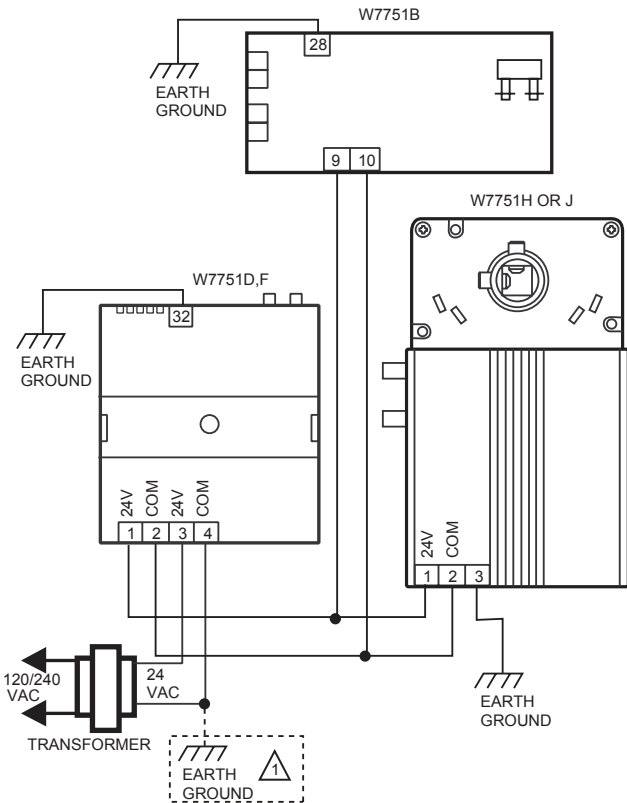

⚠ IF THE W7751 CONTROLLER IS USED IN UL 1995 EQUIPMENT AND THE PRIMARY POWER IS MORE THAN 150 VOLTS, GROUND ONE SIDE OF TRANSFORMER SECONDARY.

M10524A

Fig. 10. Power wiring for multiple controllers.

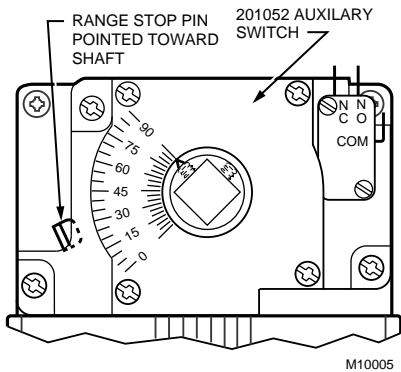

Fig. 11. 201052 Auxiliary Switch mounted on W7751H.

NOTES:

- If a range stop pin is used, it must be pointing inward toward the shaft (see Fig. 11) to allow clearance for the auxiliary switch.
- Each switch is independently adjustable in two-degree increments to any point within the travel of the actuator. Switches have a fixed differential of approximately three angular degrees.

PROCEDURE

1. Determine desired switching action (i.e., if switch energizing is to occur during CW or CCW rotation). With switch cam as shown in Fig. 12, the normally closed contact opens in CCW rotation. The normally open contact closes. Conversely, with switch cam as shown in Fig. 13, the normally closed contact opens during CW rotation and the normally open contact closes.

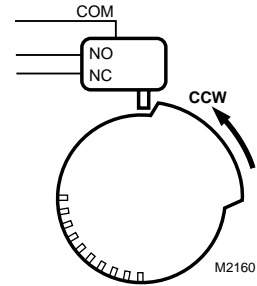

Fig. 12. Switching configuration for CCW rotation (top view).

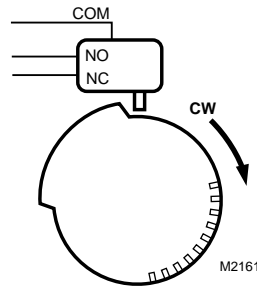
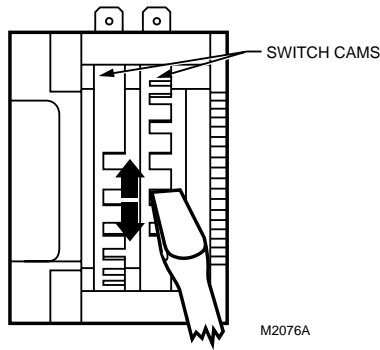

Fig. 13. Switching configuration for CW rotation (top view).

2. Align switch hub with actuator set screws. Mount switch on actuator and tighten the three captive screws.
3. Connect controller with laptop PC. To do this, the controller on the W7751H must be wired, powered, and connected to the portable PC via the SLTA. The SLTA connects to the controller on the W7751H via Network Access Jack on the T7770 Wall Module or by B-Port on the Q7750A Zone Manager. From E-Vision Software, drive the W7751H actuator and halt the motion at the desired position for switch operation.

NOTE: When installed, angular position indicator on the switch face moves from 90 to 0 degrees during CCW motion and from 0 to 90 degrees during CW motion.

4. Once finished programming, disconnect the portable PC.
5. With a screwdriver, move the cam inside the switch assembly to the appropriate position, remembering cam travel direction for switching purposes (see Fig. 14) when turning switch on or off. Monitor switch closure with ohmmeter for a continuity check. Normally closed contact should measure zero ohms and normally open contact should measure infinite ohms when switch is not activated. The opposite is true when switch is activated.



**Fig. 14. Auxiliary switch cam adjustment.**

NOTE: For 2 or 3 switch models, cams align with their respective switches and are individually set - using the same procedure described above.

5. Ensure switch activation at the desired degree of stroke by commanding the actuator to both fully open and fully closed; see step 3.

NOTE: Switches can also be preset prior to actuator installation if angular switch position is known.

**Communications**

Refer to *LONWORKS® Bus Wiring Guidelines, form 74-8565*, for complete description of LONWORKS® Bus network topology rules.

If a longer LONWORKS® Bus network is required, a Q7740A 2-way or Q7740B 4-way repeater can be added to extend LONWORKS® Bus length, only if this is an Energy Management (PAZX) Bus.

**IMPORTANT**

*The Q7740A,B Repeaters cannot be used in smoke control applications.*

A Q7751A Router can only be added to an Energy Management Bus to partition system into two segments (effectively doubling LONWORKS® Bus length). Only one router is allowed with each Excel 10 Zone Manager (or Excel 15 Building Manager), and each network segment can have a maximum of one repeater.

Pull the cable to each device on the LONWORKS® Bus and connect to communication terminals 11 and 12 (W7751H).

**IMPORTANT**

*Screw type terminal blocks are designed to accept no more than one 14 AWG (2.0 mm<sup>2</sup>) conductor. Multiple 14 AWG (2.0 mm<sup>2</sup>) wires can be connected with a wire nut. Include a pigtail with this wire group and attach the pigtail to the individual terminal block.*

Notes on LonWorks® Bus Communications Wiring:

- All field wiring must conform to local codes and ordinances (or as specified on the installation drawings).

- Approved cable type is Level IV 22 AWG (0.34 mm<sup>2</sup>) plenum or non-plenum rated unshielded, twisted pair, solid conductor wire:
  - For nonplenum areas, use CMP listed cable.
  - In plenum areas, use CMP listed cable.
- Unswitched 24 vac power-limited wiring or sensor wiring can be run in the same conduit as the LONWORKS® Bus cable.
- Do not bundle output wires with sensor, digital input or LONWORKS® Bus wires.
- Ensure that neither LONWORKS® Bus wire is grounded.
- In noisy (high EMI) environments, avoid wire runs parallel to noisy power cables, motor control centers, or lines containing lighting dimmer switches. Keep at least 3 in. (76 mm) of separation between noisy lines and LONWORKS® Bus cable.
- Do not use different wire types or gauges on the same LONWORKS® Bus segment:
  - Step changes in line impedance characteristics cause unpredictable reflections on the LONWORKS® Bus.

**Wiring Details**

Wire to the terminal blocks as follows:

1. Strip 3/16 in. (5 mm) insulation from the conductor.
2. Insert the wire in the required terminal location and tighten the screw to complete the termination.

NOTE: With the exception of 14 AWG (2.0 mm<sup>2</sup>), if inserting two or more wires into one terminal location, twist wires together before inserting them. See Fig. 15. Deviation from this rule can result in improper electrical contact.

The controller on the W7751H has the terminal arrangement shown in Fig. 16. Fig. 16 through 21 provide detailed wiring diagrams for the W7751H. Refer to installation diagrams for specific wiring.

NOTE: Ensure Configuration DIP Switch is set as shown in Fig. 19. Switches 1 through 3 set ML7984B Valve Actuator timing to match W7751H outputs (0.1 sec. minimum with maximum time of 25.6 sec.). Switch 4 determines actuator action (Off = Direct Acting, On = Reverse Acting).

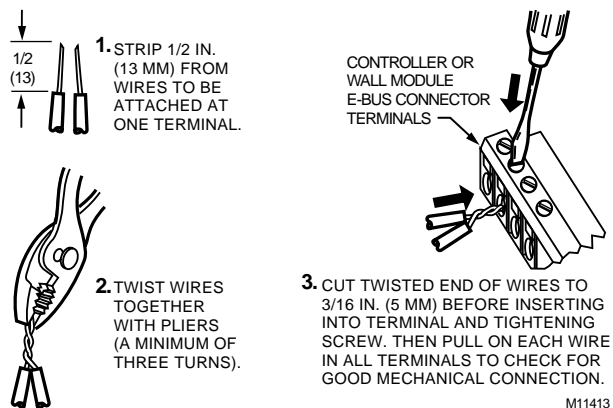

**Fig. 15. Attaching two or more wires at terminal blocks.**

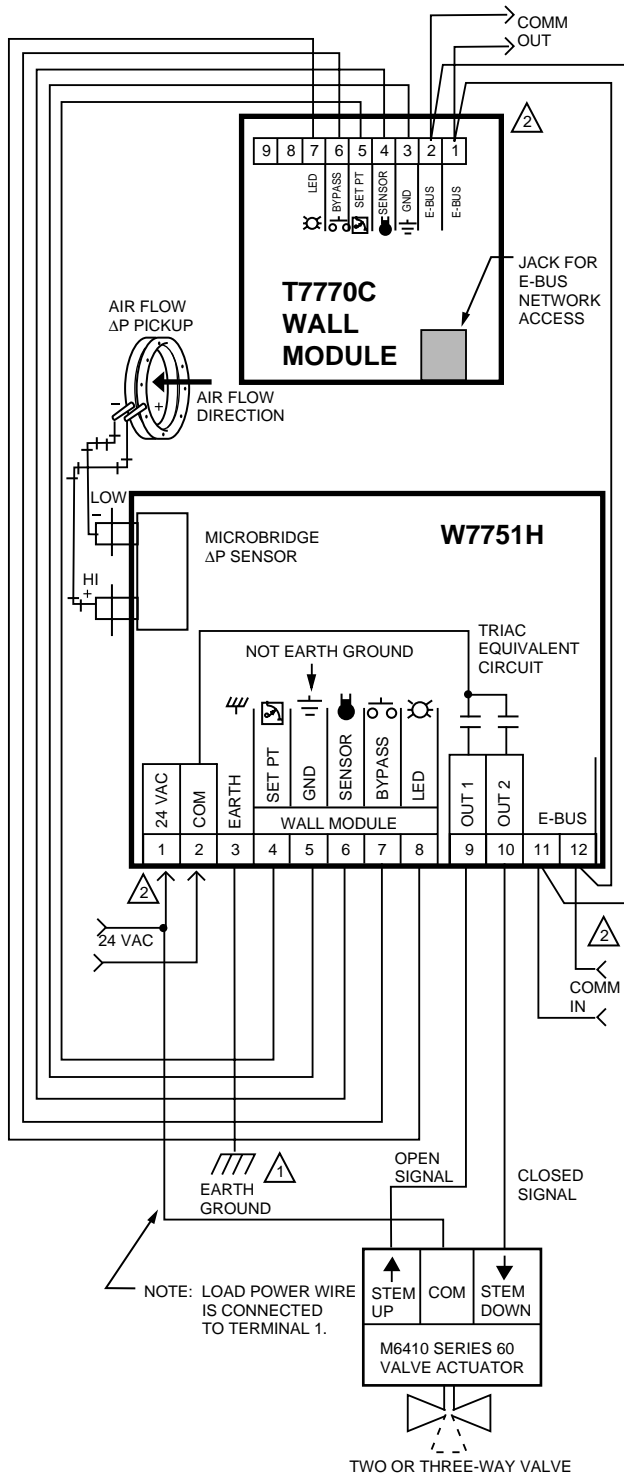

**Fig. 16. W7751H modulating reheat valve wiring diagram.**  
(For Note 2 instructions, refer to Fig. 15.)

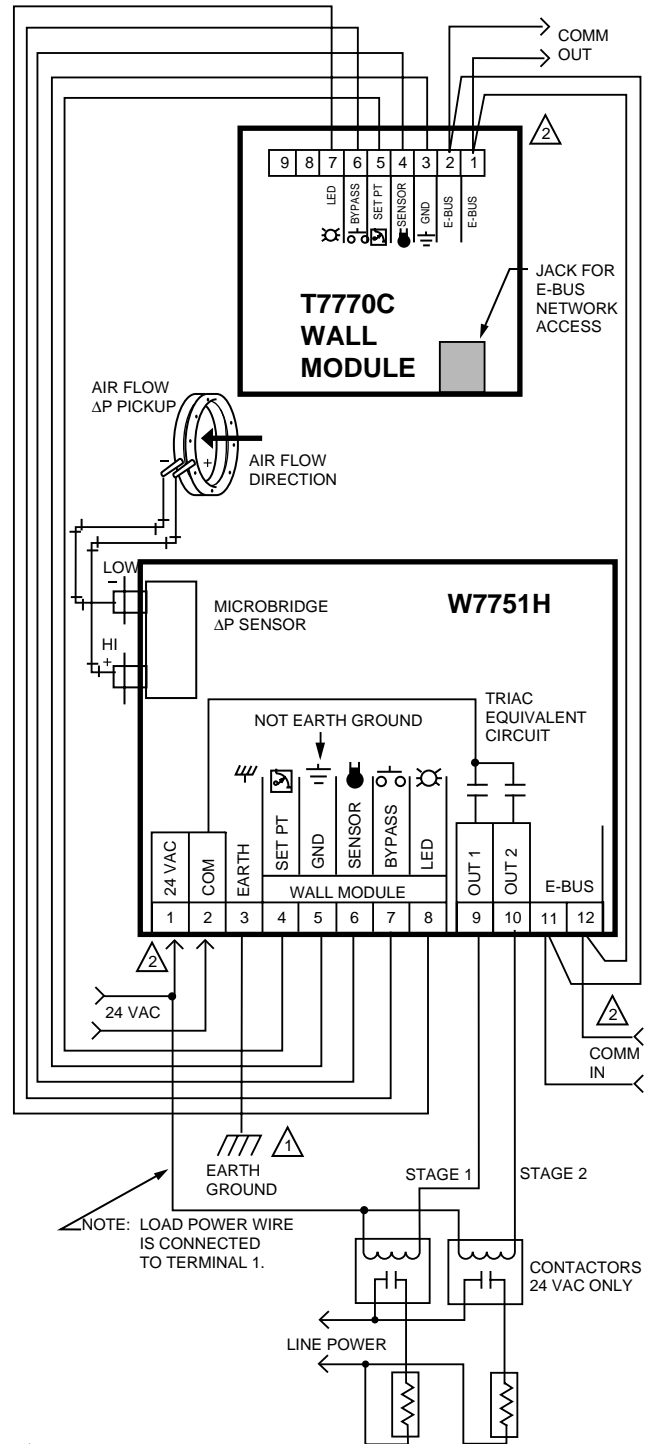

**Fig. 17. W7751H 2-stage reheat wiring diagram.**  
(For Note 2 instructions, refer to Fig. 15.)

⚠️ EARTH GROUND WIRE LENGTH SHOULD BE HELD TO A MINIMUM. USE THE HEAVIEST GAUGE WIRE AVAILABLE, UP TO 14 AWG (2.0 MM<sup>2</sup>) WITH A MINIMUM OF 18 AWG (1.0 MM<sup>2</sup>), FOR EARTH GROUND WIRE.

⚠️ TO ASSURE PROPER ELECTRICAL CONTACT, WIRES MUST BE TWISTED TOGETHER BEFORE INSERTING INTO THE TERMINAL BLOCK.

M10525

⚠️ EARTH GROUND WIRE LENGTH SHOULD BE HELD TO A MINIMUM. USE THE HEAVIEST GAUGE WIRE AVAILABLE, UP TO 14 AWG (2.0 MM<sup>2</sup>) WITH A MINIMUM OF 18 AWG (1.0 MM<sup>2</sup>), FOR EARTH GROUND WIRE.

⚠️ TO ASSURE PROPER ELECTRICAL CONTACT, WIRES MUST BE TWISTED TOGETHER BEFORE INSERTING INTO THE TERMINAL BLOCK.

M10526



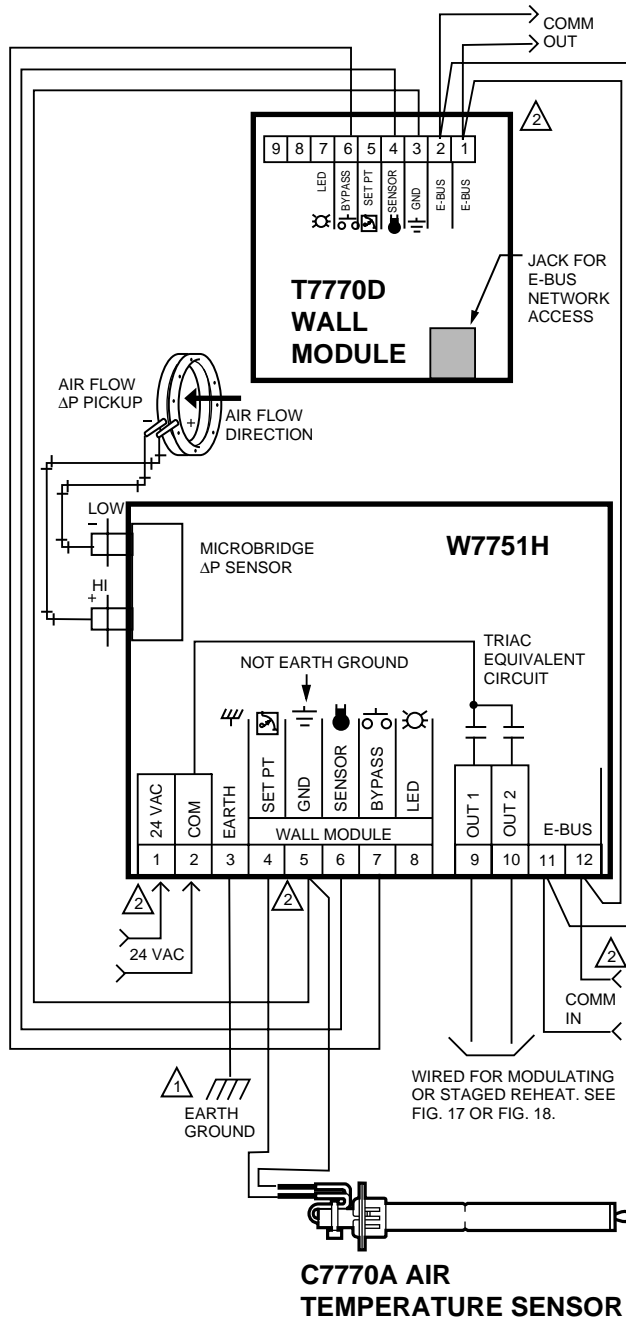

- ⚠ EARTH GROUND WIRE LENGTH SHOULD BE HELD TO A MINIMUM. USE THE HEAVIEST GAUGE WIRE AVAILABLE, UP TO 14 AWG (2.0 MM<sup>2</sup>) WITH A MINIMUM OF 18 AWG (1.0 MM<sup>2</sup>), FOR EARTH GROUND WIRE.
  - ⚠ TO ASSURE PROPER ELECTRICAL CONTACT, WIRES MUST BE TWISTED TOGETHER BEFORE INSERTING INTO THE TERMINAL BLOCK.
  - ⚠ NOTE: AIR TEMPERATURE SENSOR CANNOT BE USED WITH EITHER THE T7750B OR C WALL MODULE.
- M10527A

**Fig. 18. W7751H discharge air sensing**  
(For Note 2 instructions, refer to Fig. 15.)

## CHECKOUT

### W7751H Checkout

#### Step 1. Wiring Connections

Inspect all wiring connections at the W7751H and the T7770 terminals, and verify compliance with installation diagrams. If any wiring changes are required, *first* be sure to remove power from the controller *before* starting work. Pay particular attention to:

- 24 Vac power connections. Verify multiple controllers being powered by the same transformer are wired through the transformer secondary connected to the same input terminal numbers on each W7751. See Fig. 10. (Controller configurations are not necessarily limited to three devices, but the total power draw including accessories cannot exceed 100 VA when powered by the same transformer. See System Engineering form 74-2949 for power wiring recommendations.)
- Controller wiring. Be sure that each controller is wired (terminal 3 on the W7751H, 28 on the W7751B, and 32 on the W7751D,F) to a verified earth ground using a wire run as short as possible with the heaviest gauge wire available, up to 14 AWG (2.0 mm<sup>2</sup>) with a minimum of 18 AWG (1.0 mm<sup>2</sup>) for each controller in the group. See Fig. 10.
- Verify Triac wiring to external devices uses the proper load power/24 Vac Hot terminal (terminal 1 on the W7751H).

NOTE: All wiring must comply with applicable electrical codes and ordinances. Refer to installation diagrams for specific wiring.

#### Verify Termination Module Placement

The installation wiring diagrams should indicate the locations for placement of Termination Module(s). Refer to the *LONWORKS® Bus Wiring Guidelines*, form 74-2865, and the *Excel 10 FTT Termination Module Installation Instructions*, form 95-7554. Correct placement of the termination module(s) is required for proper LONWORKS® Bus communications.

#### Step 2. Startup

##### Broadcasting the Service Message

The Service Message allows a device on the LONWORKS® Bus to be positively identified. The Service Message contains the controller neuron ID number and, therefore, can be used to confirm the physical location of a particular Excel 10 in building.

There are three methods of broadcasting the Service Message from an Excel 10 W7751H Controller:

1. Physical service pin on controller:
  - a. Remove the plastic cover and the white button is located next to the terminal strip.
  - b. Momentarily pressing this service pin broadcasts the Service Message on the network.
2. Using the wall module bypass pushbutton:
  - a. By pressing the wall module bypass/override button for more than four seconds, the controller sends the Service Message.
  - b. This functionality is supported in firmware version 1.2.15 or higher.

NOTE: During item 2, the occupancy override state of the controller changes based on how long the bypass/override button is depressed. For example, if the button is pressed for 6 sec., the node sends the Service Pin Message, AND the node enters Continuous Unocc mode. To clear Continuous Unocc mode, the button must be pressed momentarily.

3. The following method is only supported on E-Vision and LONSPEC™:
  - a. When an Assign ID command is issued from the Honeywell Software listed, the node enters the SERVICE\_MESSAGE mode for five minutes.
  - b. In this mode, pressing the bypass/override button causes the Service Message to be broadcast on the network.
  - c. All other functions are normal in this mode.
  - d. If the bypass/override button is not available, shorting the controller Bypass Input terminals (on W7751H short terminals 5 and 7) broadcasts the Service Message.

### Alarms

The commissioning tool is used to perform the ID Assignment task. Once the ID Assignment and commissioning has been done, check the controller status LED to determine if there are any alarms.

### W7751 Controller Status LED

The LED on the front of a W7751H Controller (located just under the plastic cover), provides a visual indication of the status of the device. When the W7751H receives power, the LED appears in one of the following allowable states:

1. Off—no power to the processor.
2. Continuous on—processor is in initialized state.
3. Slow blink—controlling, normal state.
4. Fast blink—when the Excel 10 VAV Controller has an alarm condition.

When an Excel 10 has an alarm condition, it reports it to the central node on the LONWORKS® Bus. Also, the Excel 10 VAV Controller variables, *AlarmLogX*, where X is 1 through 5, that store the last five alarms to occur in the controller, are available. These points can be viewed through workstation software. Refer to the VAV System Engineering Guide form, 74-2949 Table 12 for a description of the Excel 10 Alarms.

NOTE: The node can be reset by switching the node to MANUAL and then to the normal operating mode.

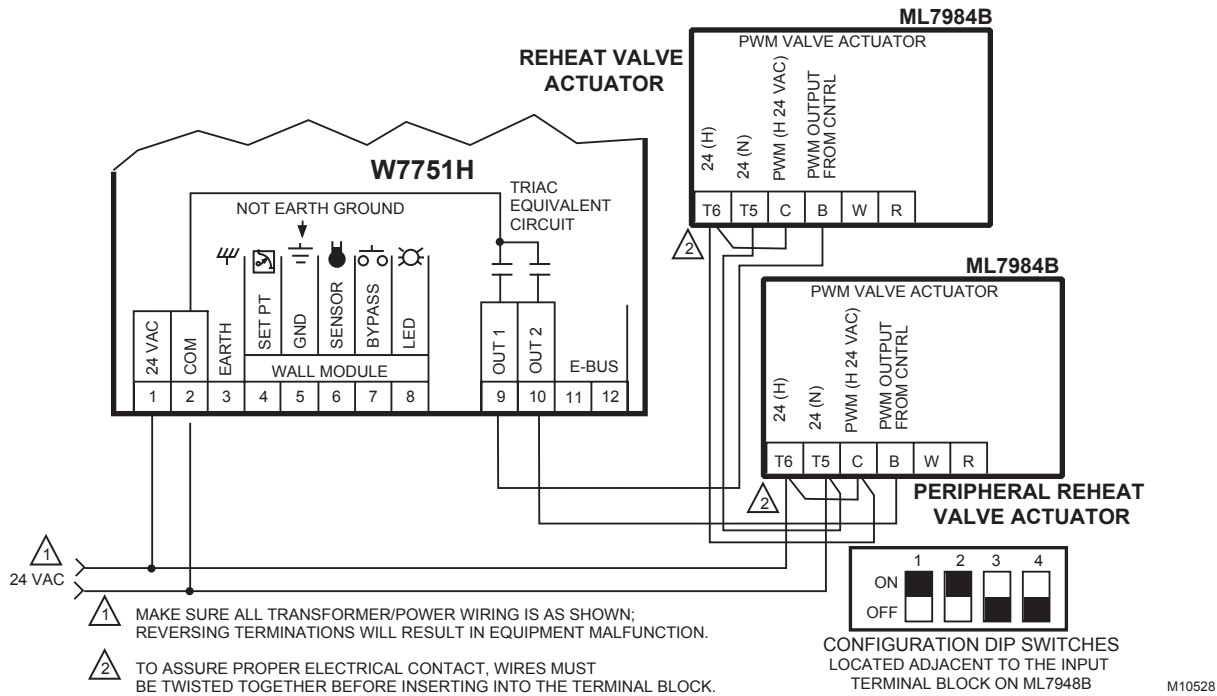

Fig. 19. W7751H to PWM Valve Actuator.

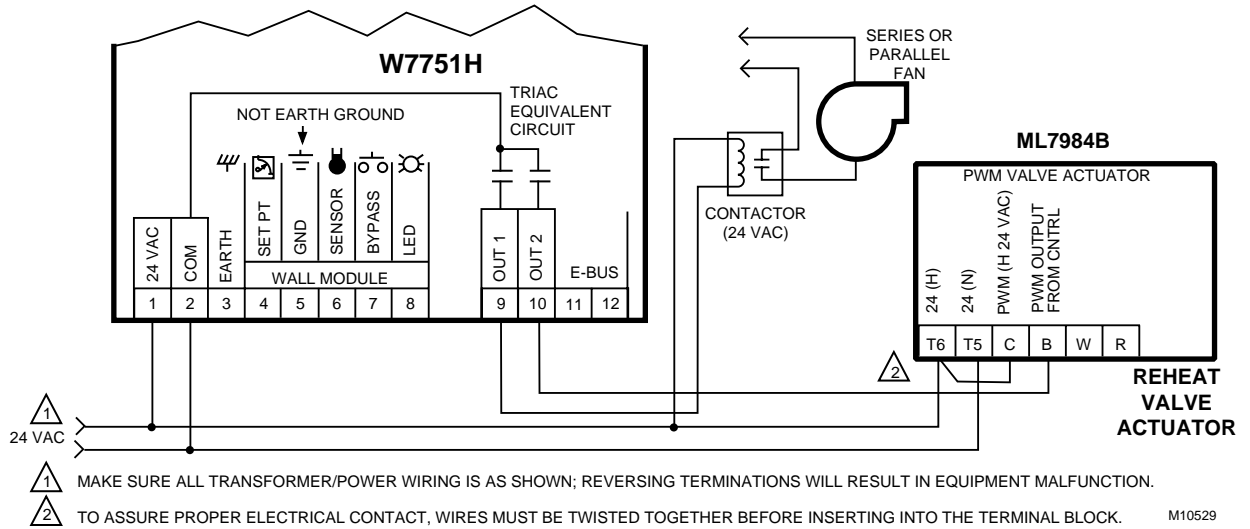

Fig. 20. W7751H to PWM Valve Actuator and series or parallel fan.

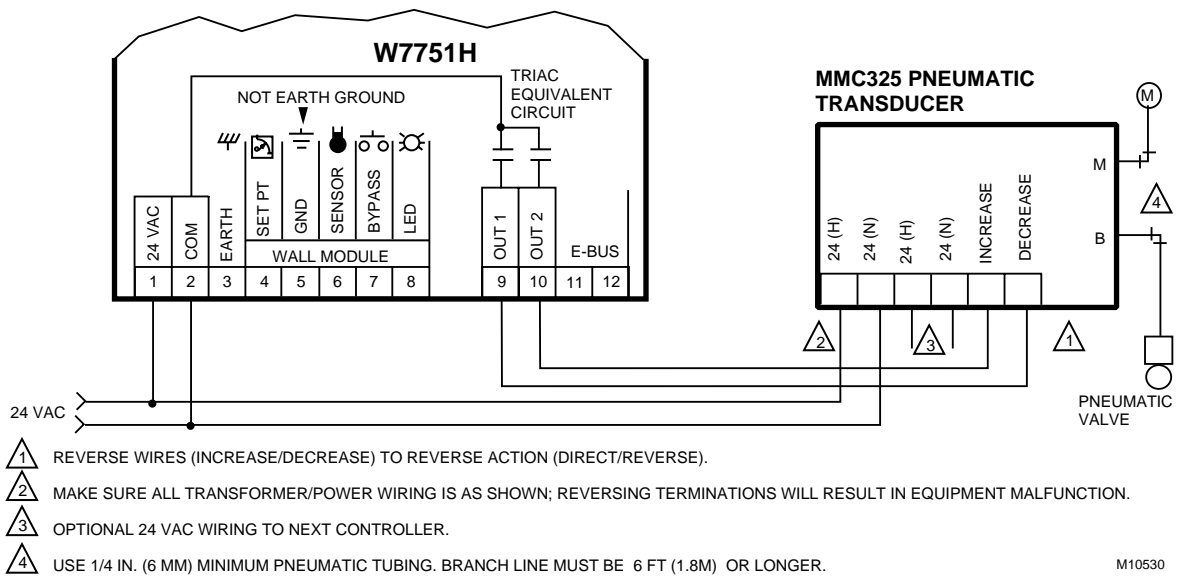

Fig. 21. W7751H to pneumatic transducer.

### T7770C or D Wall Module Override LED

The remote override LED, located on either the T7770C or T7770D Wall Module will display the Manual Override mode of the controller. The modes are:

1. LED = Off. No override active.
2. LED = Continuously On. Bypass mode (timed Occupied override).
3. LED = One flash per second. Continuous Unoccupied override.
4. LED = Two flashes per second. Remote only, continuous Occupied override.

### Step 3. I/O Tests

The controller can be configured using the LONSPEC™, or E-Vision PC configuration tool. Once this is done, the W7751H can be commanded to MANUAL mode, and each output and input can be exercised/viewed to verify proper wiring connections and equipment operation.

### W7751H Actuator Checkout

To check out the actuator on the W7751H, determine the direction the damper shaft moves to open the damper (CW or CCW). See Fig. 5.

Devices for use only if used for Energy Management: Q7740A,B and Q7751A

Devices for use on an Energy Management and/or Smoke Control:  
W7751H2025 Series 9, W7761A2010, W7751B2010, W7751D2016, W7751F2011, XLINK, Q7750, Q9200, XL500, XFL521, XFL522, XFL523, XFL524, 14507287 Series Power Supplies.

Connect the controller with the laptop PC. To do this, the controller on the W7751H must be wired, powered, and connected to the portable PC via the SLTA. The SLTA connects to the controller on the W7751H via the Jack for Network Access on T7770 Wall Modules or by the B-Port on the Q7750A Zone Manager. From LONSPEC™, or E-Vision Software, drive the actuator on the W7751H open and then closed. Observe the operation of the actuator; if the damper is closed, it should begin to open. If the damper is open, it should begin to close.

If no movement is observed, check to see if 24 Vac is present at the controller on the W7751H. With proper wiring, 24 Vac present, and proper commands from the software, the actuator should operate properly. If not, the W7751H Smart VAV Actuator may need to be replaced.

### Step 4. Verify Sequences of Operation

For the detailed descriptions of the sequences of operation, see the Excel 10 VAV System Engineering form 74-2949.

*LONWORKS® and LONTALK® are registered trademarks of Echelon® Corporation.*

*LONSPEC™ is a trademark of Echelon® Corporation.*

---

**Honeywell**

#### Automation and Control Solutions

Honeywell International Inc.	Honeywell Limited-Honeywell Limitée
1985 Douglas Drive North	35 Dynamic Drive
Golden Valley, MN 55422	Scarborough, Ontario
	M1V 4Z9

#### ACS Control Products

Honeywell AG  
Böblinger Straße 17  
D-71101 Schönaich  
Phone (49-7031) 637-01  
Fax (49-7031) 637-493