



ESPECIFICACIONES

Voltaje	110 VCA
AMP	2.75
DB	123
Peso	5 kg
IP	44
Hz	50/60

NIVEL DE PROTECCION

IP (Ingress Protection):

Índice de protección a la intervención de materiales externos

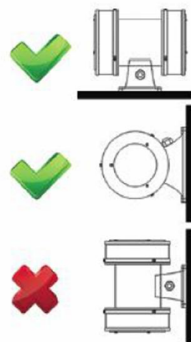
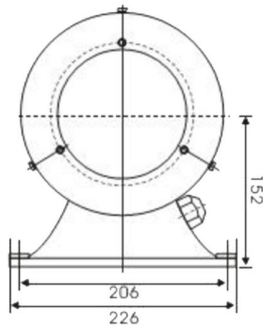
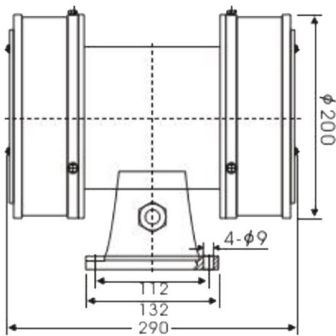
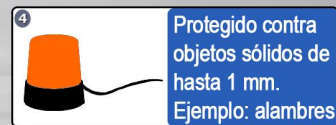

Unidad: mm

Usos

