



1. Optional Front Flange
2. Optional Back Flange

Description & Features:

- High quality, commercial grade gauge at an economical price
- $\pm 1\%$ accuracy
- Adjustable pointer
- Steel and aluminum cases
- Brass wetted parts
- CRN registered
- 5 year warranty

Applications:

- Plumbing and heating

Specifications

Dial	3.5" (90mm), 4" (100mm), 4.5" (115mm), 6" (150mm) white aluminum dial
Case	3.5" (90mm), 4" (100mm): Steel painted black 4.5" (115mm): Aluminum 6" (150mm) Bottom: Steel painted black 6" (150mm) Back: Aluminum
Lens	3.5" (90mm), 4.5" (115mm) bottom connection, 6" (150mm): Glass 4" (100mm), 4.5" (115mm) back connection: Polycarbonate
Ring	3.5" (90mm), 4" (100mm), 4.5" (115mm) bottom connection: Polished brass 6" (150mm) bottom connection: Steel painted black 4.5" (115mm) back connection, 6" (150mm) back connection: SS, polished
Socket	Brass
Connection	$\frac{1}{4}$ " NPT standard
Bourdon Tube	Phosphor bronze
Pointer	Black aluminum, adjustable
Welding	Silver alloy
Over-Pressure Limit	25% of full scale value
Working Pressure	Maximum 75% of full scale value
Ambient/Process Temperature	-40°F to 200°F (-40°C to 93°C)
Accuracy	$\pm 1\%$ ANSI/ASME Grade 1A
Enclosure Rating	IP52

P1S 100 Series Gauge

Industrial

Order Codes (products in bold are normally stock)
(products in italics are normally available in 3 - 5 days)

Dial Size	3.5" (90mm)		4" (100mm)	4.5" (115mm)		6" (150mm)	
Case Material	Steel		Steel	Aluminum		Steel	Aluminum
Connection	Bottom	Centre Back	Centre Back	Bottom	Lower Back	Bottom	Lower Back
30" Hg Vac/kPa	P1S234	<i>P1S560</i>	P1S460	P1S410	<i>P1S430</i>	P1S250	P1S475
30"/0/15 psi/kPa	P1S230	<i>P1S568</i>	P1S468	P1S411	<i>P1S431</i>	P1S251C	P1S476
30"/0/30 psi/kPa	P1S231	<i>P1S569</i>	P1S469	P1S412	<i>P1S432</i>	P1S252C	P1S477
30"/0/60 psi/kPa	P1S232	<i>P1S570</i>	P1S470	P1S413	<i>P1S433</i>	P1S259C	P1S478
30"/0/100 psi/kPa	P1S233	<i>P1S571</i>	P1S471	P1S414	<i>P1S434</i>	P1S253C	P1S479
30"/0/160 psi/kPa	P1S229	<i>P1S572</i>	P1S472	P1S416	<i>P1S436</i>	P1S254C	P1S480
30"/0/200 psi/kPa	-	<i>P1S573</i>	-	P1S417	<i>P1S437</i>	P1S255C	P1S481
30"/0/300 psi/kPa	P1S227	<i>P1S574</i>	P1S473	P1S418	<i>P1S438</i>	P1S256C	P1S482
0/15 psi/kPa	P1S228	<i>P1S561</i>	P1S461	P1S419	<i>P1S439</i>	-	-
0/30 psi/kPa	P1S235	<i>P1S562</i>	P1S462	P1S420	<i>P1S440</i>	P1S251	P1S483
0/60 psi/kPa	P1S236	<i>P1S563</i>	P1S463	P1S421	<i>P1S441</i>	P1S252	P1S484
0/100 psi/kPa	P1S237	<i>P1S564</i>	P1S464	P1S422	<i>P1S442</i>	P1S253	P1S485
0/160 psi/kPa	P1S238	<i>P1S565</i>	P1S465	P1S423	<i>P1S443</i>	P1S254	P1S486
0/200 psi/kPa	P1S239	<i>P1S566</i>	P1S466	P1S424	<i>P1S444</i>	P1S255	P1S487
0/300 psi/kPa	P1S240	<i>P1S567</i>	P1S467	P1S426	<i>P1S446</i>	P1S256	P1S488
0/600 psi/kPa	-	-	-	P1S490	-	-	-
0/1,000 psi/kPa	-	-	-	P1S491	-	-	-
0/3,000 psi/kPa	-	-	-	P1S492	-	-	-
0/5,000 psi/kPa	-	-	-	P1S493	-	-	-

Other ranges and connection sizes available upon request. For scale change, refer to How to Order Guide for scale codes. **For options, attach suffix to end of order code: i.e. P1S420-45QBF for BACK FLANGE.**

Option suffix:

35QBF = 3.5" Back flange
 4QBF = 4" Back flange

45QBF = 4.5" Back flange
 6QBF = 6" Back flange

Note: Syphon recommended for all steam applications

3.5" Bottom Connection

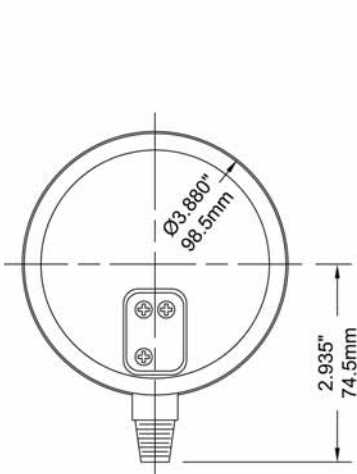

3.5" Back Connection

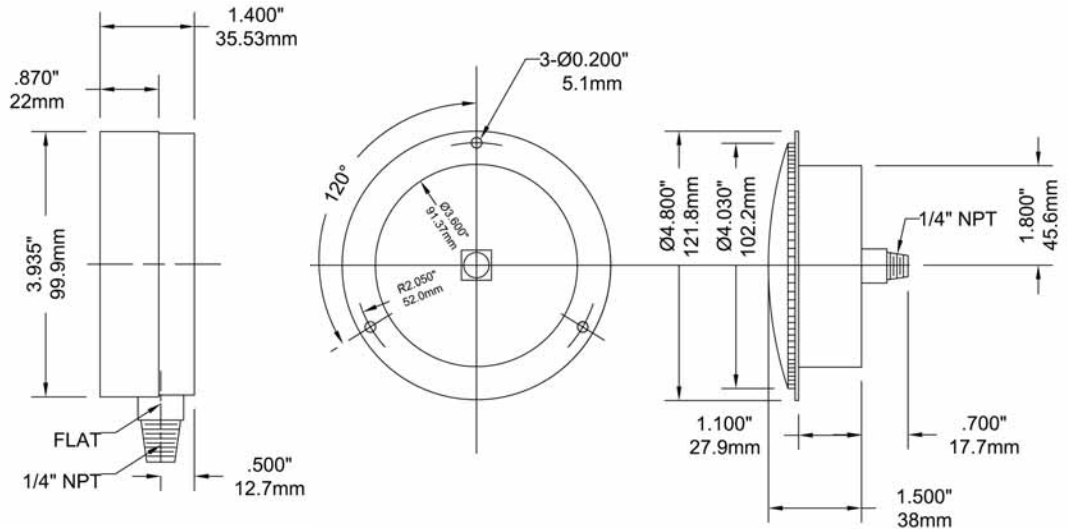

4" Centre Back Connection

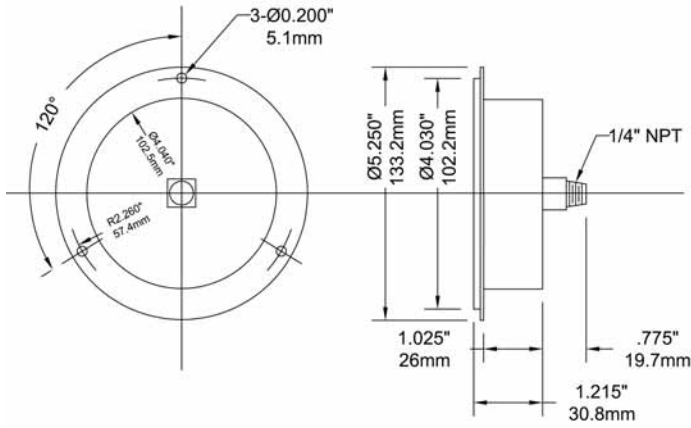

4.5" Bottom Connection

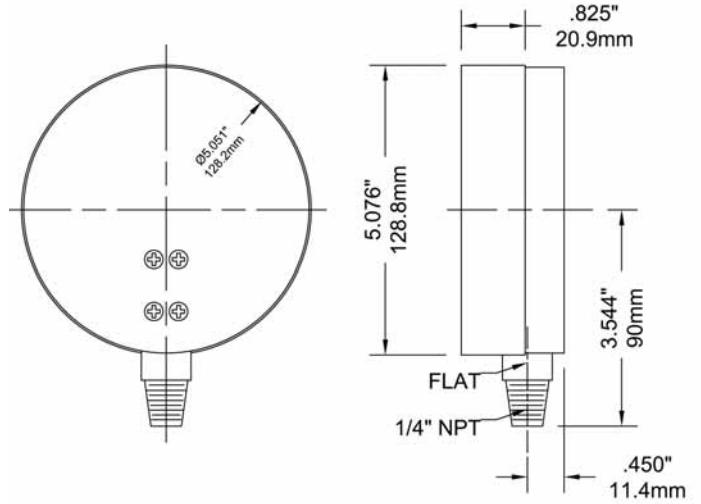

4.5" Lower Back Connection

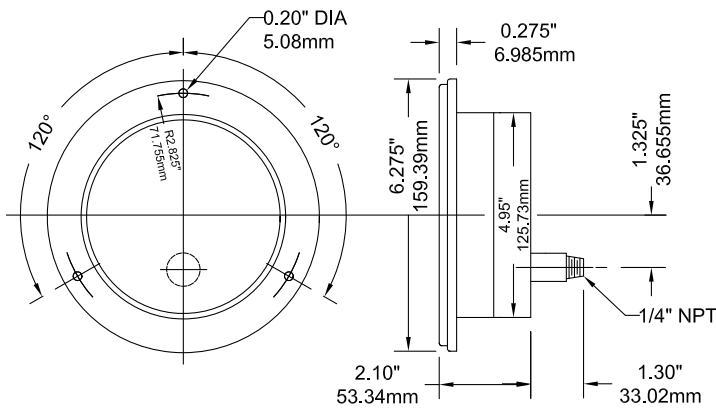

6" Bottom Connection

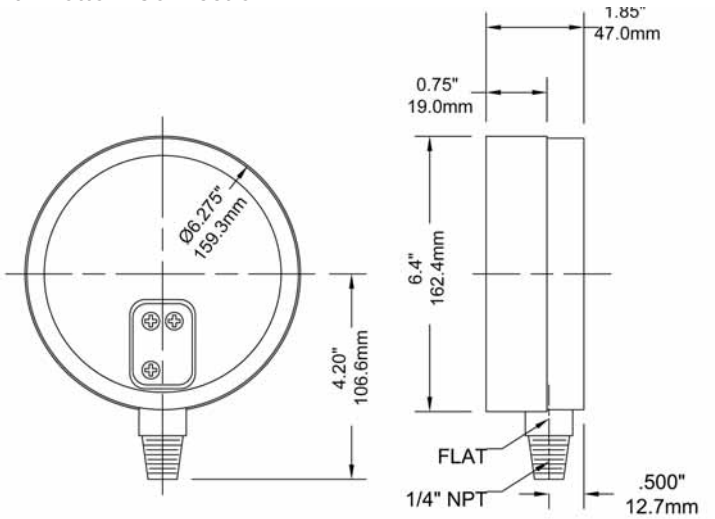

6" Back Connection with Front Flange

