

325 SERIES

Lever Acting Design

Maxitrol's 325 Series pounds to inches regulators are for use on residential, commercial, and industrial applications.

The 325 Series features a high leverage valve linkage assembly to deliver positive dead-end lockup. The regulators are capable of precise control from full flow down to pilot flow.



325-3

Specifications

- Pipe Sizes** 3/8" to 2" threaded connections with NPT or ISO7-1 threads.
- Housing Material** 325-3, 325-5, 325-7A, 325-9, 325-11: aluminum.
- Mounting** Suitable for multi-positional mounting. If ball check vent limiting device is installed, mount in an upright position only.
NOTE: All Maxitrol gas pressure regulators should be installed and operated in accordance with Maxitrol Safety Warning Instructions (see GPR_MI_EN.ES or GPR_CSA_MI_EN.FR).
- Certifications** 325-3, 325-5: ANSI Z21.18/CSA 6.3 Gas Appliance Pressure Regulators.
- Gas Types** Suitable for natural, manufactured, mixed gases, liquefied petroleum gases, and LP gas-air mixtures.
- Rated Inlet Pressure** CSA Certified: 325-3, 325-5: 2 psi (13.8 kPa), 5 psi (34.5 kPa)
- Maxitrol Tested** 325-3, 325-5, 325-7A, 325-9: 10 psi (69 kPa)
With Vent Limiter 12A09, 12A39, or 12A49 Installed:
325-3, 325-5, 325-7A, 325-9: 5 psi (34.5 kPa) - Natural, 2 psi (13.8 kPa) - LP
- Emergency Exposure Limits** 65 psi (450 kPa) (inlet side only)
- Maximum Individual Load** Largest single appliance served by the regulator: 325-3: 100,000 Btu/h;
325-5: 325,000 Btu/h; 325-7A: 1,250,000 Btu/h, 325-9: 2,250,000 Btu/h; 325-11:
4,500,000 Btu/h
- Capacity** Total load of multiple appliances combined: 325-3: 150,000 Btu/h;
..... 325-5: 325,000 Btu/h; 325-7A: 1,250,000 Btu/h; 325-9: 2,250,000 Btu/h;
325-11: 4,500,000 Btu/h
NOTE: Capacities are used to determine the maximum multiple appliance load. The largest single appliance served by the regulator should not exceed the maximum individual load specified above.
- Ambient Temperature Ranges** -40 to 205°F (-40 to 96°C)
- Minimum Regulation**..... Suitable for pilot flow applications. (P) (Circle P) (0.15 CFH NG), None (1.5 CFH NG).

APPLIANCE REGULATORS



UA.TR.012-13

TF02

Capacities: based on 1" w.c. pressure drop, from set point**

Capacities expressed in CFH (m³/h) @ 0.64 sp gr gas

Model	Pipe Size	Outlet Pressure Set Point	CSA MAX CFH	Operating Inlet Pressure					
				0.5 psi (3.4 kPa)	0.75 psi (5.2 kPa)	1 psi (6.9 kPa)	2 psi (13.8 kPa)	5 psi (34.5 kPa)	10 psi (69.0 kPa)
325-3	3/8" x 3/8" 1/2" x 1/2"	4.0" w.c. (1.0 kPa)	150 (4.2)	160 (4.5)	190 (5.4)	220 (6.2)	220 (6.2)	300 (8.5)	320 (9.1)
		7.0" w.c. (1.7 kPa)	150 (4.2)	120 (3.4)	150 (4.2)	180 (5.1)	220 (6.2)	290 (8.2)	320 (9.1)
		10.0" w.c. (2.5 kPa)	150 (4.2)	100 (2.8)	120 (3.4)	150 (4.2)	220 (6.2)	280 (7.9)	320 (9.1)
325-5	1/2" x 1/2" 3/4" x 3/4" 1" x 1"	4.0" w.c. (1.0 kPa)	325 (9.2)	340 (9.6)	390 (11.0)	450 (12.7)	560 (15.9)	680 (19.3)	750 (21.2)
		7.0" w.c. (1.7 kPa)	325 (9.2)	260 (7.4)	360 (10.2)	410 (11.6)	530 (15.0)	680 (19.3)	750 (21.2)
		10.0" w.c. (2.5 kPa)	325 (9.2)	240 (6.8)	320 (9.1)	360 (10.2)	500 (8.5)	650 (18.4)	750 (21.2)
325-7A	1 1/4" x 1 1/4" 1 1/2" x 1 1/2"	4.0" w.c. (1.0 kPa)	—	850 (24.0)	1060 (30.0)	1190 (33.7)	1600 (45.3)	2090 (59.2)	2190 (62.0)
		7.0" w.c. (1.7 kPa)	—	780 (22.0)	950 (26.9)	1060 (30.0)	1500 (42.5)	1860 (52.7)	2060 (58.3)
		10.0" w.c. (2.5 kPa)	—	650 (18.4)	860 (24.4)	990 (28.0)	1300 (36.8)	1620 (45.9)	2060 (58.3)
325-9	1 1/2" x 1 1/2" 2" x 2"	4.0" w.c. (1.0 kPa)	—	1815 (51.4)	2075 (58.8)	2250 (63.7)	2660 (75.3)	3550 (100.5)	3750 (106.2)
		7.0" w.c. (1.7 kPa)	—	1430 (40.5)	1660 (47.0)	1960 (55.5)	2570 (72.8)	3420 (96.8)	3750 (106.2)
		10.0" w.c. (2.5 kPa)	—	1275 (36.1)	1450 (41.1)	1720 (48.7)	2160 (61.2)	3150 (89.2)	3750 (106.2)
325-11	1 1/2" x 1 1/2" 2" x 2"	4.0" w.c. (1.0 kPa)	—	2650 (75.0)	3400 (96.3)	4020 (113.8)	5370 (152.1)	7950 (225.1)	11900 (337.0)
		7.0" w.c. (1.7 kPa)	—	1800 (51.0)	2770 (78.4)	3460 (98.0)	5040 (142.7)	7700 (218.0)	11600 (328.5)
		10.0" w.c. (2.5 kPa)	—	1450 (41.1)	2400 (68.0)	3190 (90.3)	4800 (135.9)	7500 (212.4)	11400 (322.8)

NOTE: Maximum Individual Load: 325-3(B) is 100 CFH (2.8 m³/h); 325-5(B) is 325 CFH (9.2 m³/h); 325-7A(B) is 1250 CFH (35.4 m³/h); 325-9(B) is 2250 CFH (63.7).

Approval based on use as an appliance regulator. **Set points (in CFH): 325-3(B) = 50; 325-5(B) = 150; 325-7A(B) = 500; 325-9(B) = 1000; 325-11(B) = 2000.

See pages 58-59 for Regulator Sizing Requirements and Examples.

Spring Selection Chart: inches w.c. (kPa) unless noted

Model Number	CSA Certified				Standard Spring	Other Springs Available			
	2 psi (13.8 kPa)		5 psi (34.5 kPa)			2 to 6	10 to 22	15 to 30	1 to 2 psi
325-3	5 to 9 (1.25 to 2.25) Plated	7 to 11 (1.7 to 2.7) White	6 to 10 (1.5 to 2.5) Plated	7 to 11 (1.7 to 2.7) White	4 to 12 (1.0 to 3.0) Violet	2 to 6 (0.5 to 1.5) Plated	10 to 22 (2.5 to 5.5) Red	15 to 30 (3.7 to 7.5) Yellow	1 to 2 psi (6.9 to 13.9) Tagged
325-5	5 to 9 (1.25 to 2.25) Plated	7 to 11 (1.7 to 2.7) White	6 to 10 (1.5 to 2.5) Plated	7 to 11 (1.7 to 2.7) White	4 to 12 (1.0 to 3.0) Violet	2 to 6 (0.5 to 1.5) Plated	10 to 22 (2.5 to 5.5) Red	15 to 30 (3.7 to 7.5) Yellow	1 to 2 psi (6.9 to 13.9) Tagged
325-7A	—	—	—	—	4 to 12 (1.0 to 3.0) Violet	2 to 5 (0.5 to 1.5) Plated	10 to 22 (2.5 to 5.5) Red	15 to 30 (3.7 to 7.5) Yellow	20 to 42 (5.0 to 10.4) Black
325-9	—	—	—	—	4 to 12 (1.0 to 3.0) Violet	2 to 5 (0.5 to 1.5) Plated	10 to 22 (2.5 to 5.5) Red	15 to 30 (3.7 to 7.5) Yellow	20 to 42 (5.0 to 10.4) Black
325-11	—	—	—	—	4 to 12 (1.0 to 3.0) Violet	2 to 5 (0.5 to 1.5) Plated	10 to 22 (2.5 to 5.5) Red	15 to 30 (3.7 to 7.5) Yellow	20 to 42 (5.0 to 10.4) Black

NOTE: See pages 56-57 for complete Spring Selection Chart.

325 SERIES

Lever Acting Design

Pressure Drop: 0.64 sp gr gas expressed in CFH (m³/h) (for system pressure drop calculations)

Model	7.0" w.c. (1.7 kPa)	0.5 psi (3.4 kPa)	0.75 psi (5.2 kPa)	1 psi (6.9 kPa)	2 psi (13.8 kPa)
325-3	145 (4.0)	204 (5.8)	250 (7.0)	289 (8.2)	—
325-5	400 (11.3)	550 (15.6)	670 (19.0)	770 (21.8)	—
325-7A	815 (23.1)	1149 (32.5)	1405 (39.8)	1624 (46.0)	2305 (65.3)
325-9	1360 (38.5)	2113 (59.8)	2557 (72.4)	2949 (83.5)	4059 (114.8)
325-11	3000 (85.0)	4220 (119.5)	5170 (146.4)	6000 (170.0)	8485 (240.3)

Dimensions

Model	Pipe Size	Vent Connection	Swing Radius	Dimensions		
				A	B	C
325-3	3/8", 1/2"	1/8" NPT	3" (76 mm)	3.5" (89 mm)	4.2" (108 mm)	3.9" (98 mm)
325-5	1/2", 3/4", 1"	3/8" NPT	4.9" (124 mm)	5.3" (133 mm)	5.9" (149 mm)	5.4" (138 mm)
325-7A	1 1/4", 1 1/2"	1/2" NPT	6.1" (156 mm)	7.3" (184 mm)	8" (203 mm)	7" (178 mm)
325-9	1 1/2", 2"	1/2" NPT	7.8" (198 mm)	9.4" (239 mm)	10.8" (274 mm)	9.1" (231 mm)
325-11	2", 2 1/2"	3/4" NPT	11.0" (279 mm)	13.1" (333 mm)	16.1" (409 mm)	13.5" (343 mm)

NOTE: Dimensions are maximums and to be used only as an aid in designing clearance for the valve. Actual production dimensions may vary somewhat from those shown.

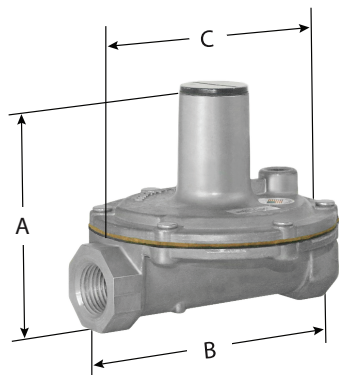

325-3

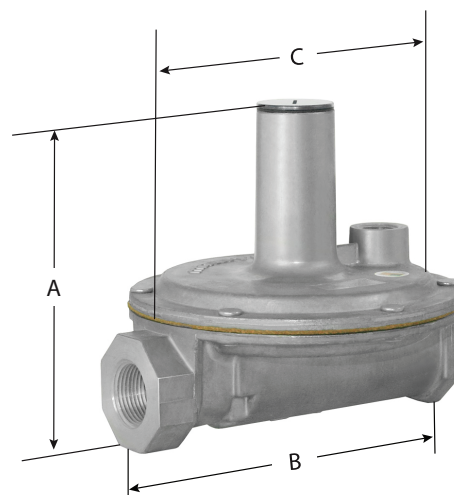

325-5

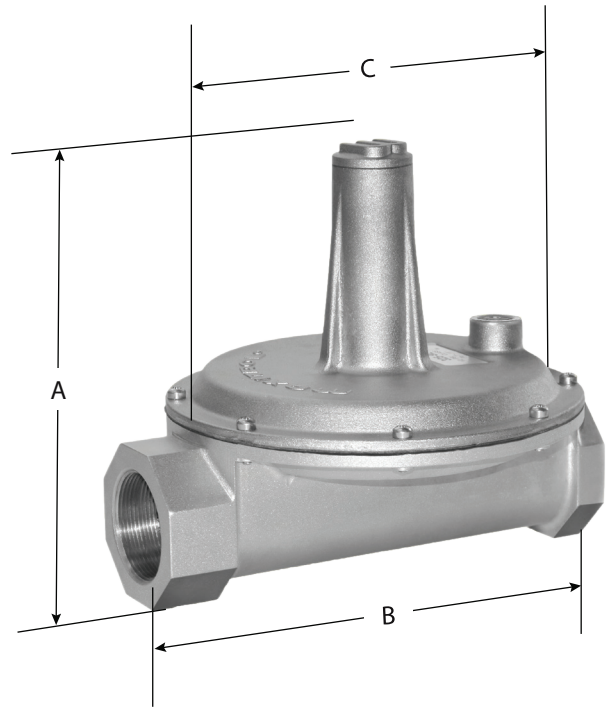
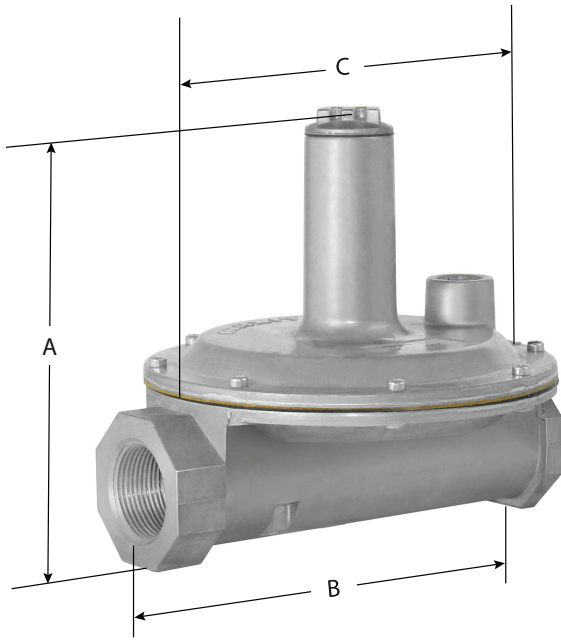

Lever Acting Design

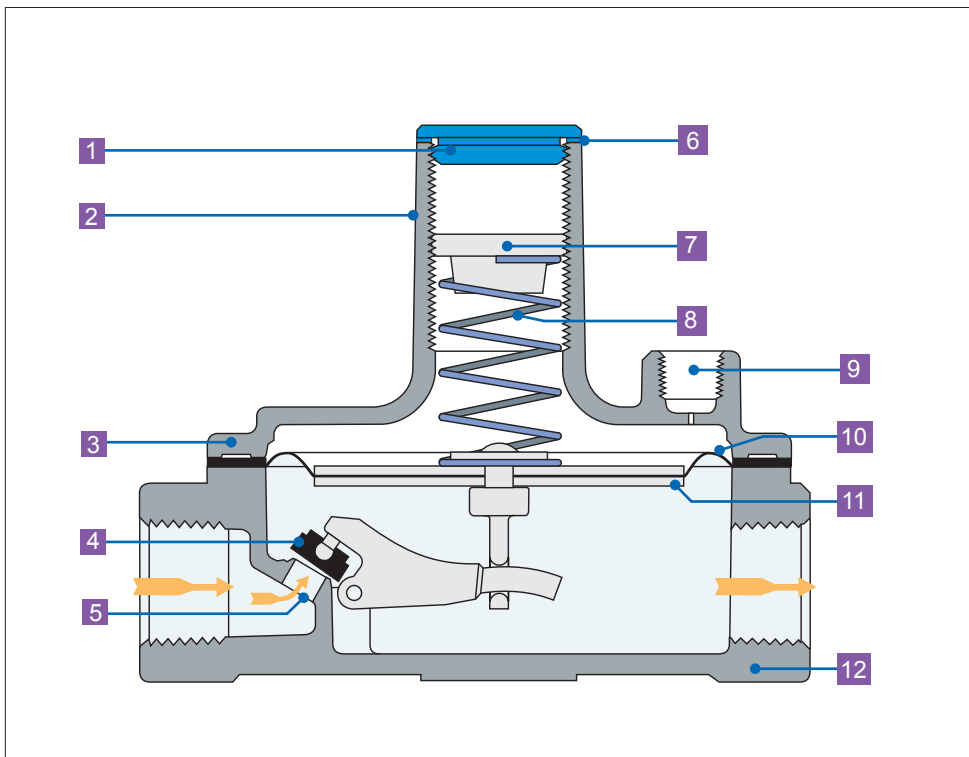

- 1 Seal Cap
- 2 Stack
- 3 Top Housing
- 4 Rubber Valve
- 5 Valve Seat
- 6 Seal Cap Gasket
- 7 Adjusting Screw
- 8 Spring
- 9 Vent Connection
- 10 Diaphragm
- 11 Diaphragm Plates
- 12 Bottom Housing

NOTE: Diagrams are graphical representations only and may differ from actual product.