

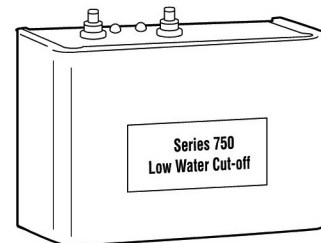

Series 750 Low Water Cut-Off For Use with Remote Sensors

Applications:





- Primary conductance type control for commercial or industrial hot water boilers where remote level sensing is required.
- Secondary control for commercial or industrial steam boilers.



Series 750



WARNING

	<ul style="list-style-type: none"> • Before using this product read and understand instructions. • Save these instructions for future reference. • All work must be performed by qualified personnel trained in the proper application, installation, and maintenance of plumbing, steam, and electrical equipment and/or systems in accordance with all applicable codes and ordinances. • Boiler manufacturer schematics should always be followed. In the event that the boiler manufacturer's schematic does not exist, or is not available from the boiler manufacturer, refer to the schematics provided in this document. • To prevent serious burns, allow the control and surrounding equipment to cool to 80° F (27° C) and allow pressure to release to 0 psi (0 bar) before servicing. • To prevent electrical fire or equipment damage, electrical wiring insulation must have a rating of 167° F (75° C) if the liquid's temperature exceeds 180° F (82° C). • This low water cut-off must be installed in series with all other limit and operating controls installed on the boiler. After installation, check for proper operation of all of the limit and operating controls, before leaving the site. • When using mixed voltages, do not jumper from terminal 1 to terminal 3. • To prevent electrocution, when the electrical power is connected to the control, do not touch the terminals, or electrical wires. • To prevent electrical shock, turn off the electrical power before making electrical connections. • California Proposition 65 warning! This product contains chemicals known to the state of California to cause cancer and birth defects or other reproductive harm. • Previous controls should never be installed on a new system. Always install new controls on a new boiler or system. <p>Failure to follow this warning could cause property damage, personal injury or death.</p> <p>CAUTION:</p> <ul style="list-style-type: none"> • A more frequent replacement interval may be necessary based on the condition of the unit at time of inspection. McDonnell & Miller's warranty is one (1) year from date of installation or two (2) years from the date of manufacture.
	
	
	
	

SPECIFICATIONS

The Series 750 control box connected to a remote sensor provides protection against low water conditions for commercial and industrial applications. The Series 750 control box is fully CSD-1 compliant and can be used as the primary LWCO on hot water boilers and as the secondary LWCO (manual reset) on steam boilers.

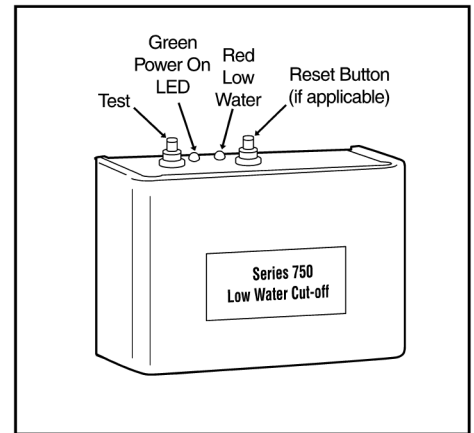

Automatic Reset Models

Whenever water is below the level of the probe, the control will go into a low water condition. When the water level has been restored, the control will automatically return to a run condition.

Manual Reset Models

If a low water condition occurs (water off probe), the manual reset button must be pressed once the water level is restored to a level above the probe.

Manual Reset units follow CSD-1 Code Compliance.

Control Unit

Temperature Ratings:

Storage: -40°F to 135°F (-40°C to 57°C)

Ambient: 32°F to 120°F (0°C to 49°C)

Humidity: 85% (non-condensing)

Electrical Enclosure Rating: NEMA 1 General Purpose

CSD-1 Code Compliance

On Manual Reset Units, if the control is in low water condition (water is off the probe) and there is a sudden power interruption, the control will remain in low water condition (Burner Off) even if the power is restored. The Reset Button must be depressed to make the control back to function, after the water level is re-established to the probe.

Lock Out Delay

When a low water condition occurs the burners turns off and Red LED begins to blink. When the water level is restored to a level above the probe within 30 sec, the boiler will return to the normal operation. If the water level remains in low condition, control will go to a low water condition and Red LED will be solid Red.

Electrical Specifications

Model	Control Voltage	Switch Contact Rating (Pilot Duty)
750-MT-24	24VAC	50VA@24VAC Or 125VA@120VAC
750-T-24		
750-MT-120	120VAC	
750-T-120		

Hz: 50/60

Control Power Consumption: 3 VA (max.)

Probe Sensitivity: 20,000 ohm

(water/glycol mixtures up to 50% concentration may be used)

STEP 1 - Where to Install the Remote Sensors

Determine where to install the remote sensor based on the following requirements:

- a. The tip of the probe or extension **must be installed above the minimum safe water level**, as determined by the boiler manufacturer.
- b. Probes must be installed vertically if they are more than 5" (127mm) long.
- c. There must be a minimum 1/4" (6.4mm) clearance between the probe and any grounding surface inside the boiler.

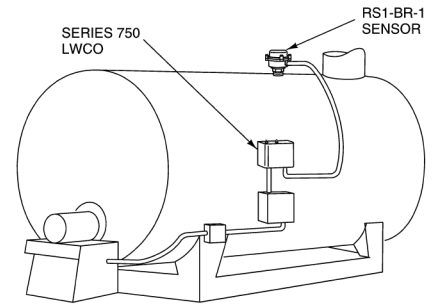
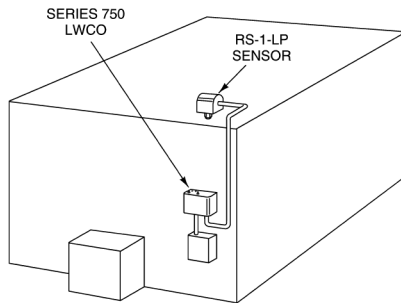

IMPORTANT: Remote sensors **MUST** be installed in a tapping on the boiler.

Table 2. Remote Sensors

Catalog No.	Part No.	Sensor Boiler Tapping	Sensor Housing	Sensor Pressure Rating (psig)	Sensor Temp. Rating °F
RS-1-LP	176203	3/4" NPT	NEMA 1	160 (water)/15 (steam)	250°
RS-1-BR-1*	179524	1" NPT	NEMA 4X	250 (water & steam)	406°

* Requires probe extension (See table 3).

Table 3. Stainless Steel Probe Extensions*

Catalog No.	Part No.	Length, Inches
RS-1/3-SS	176208	4-1/2
PS-1-SS	179530	12
G-2-SS	179156	24
G-3-SS	179157	36

* To be used with remote sensor (RS-1-BR-1) mounted in vertical position only.

REMOTE SENSORS

RS-1-LP (15 psi Steam or 160 Psi Hot Water, Max.) RS-1-BR-1 (250 Psi Steam or Hot Water, Max.)

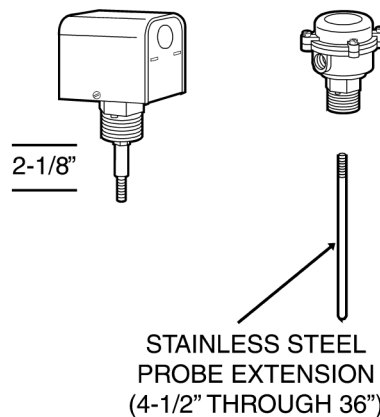

STEP 2 - Installing the Remote Sensor

For the Model RS-1-BR-1 sensors, only:

- a. Cut the probe to desired length. Screw, clockwise, the threaded stainless steel probe extension (A) into the remote sensor (B). Carefully tighten the locking nut to approximately 1 ft•lb (1.7 N•m). Do not cut the clear plastic protective tube.

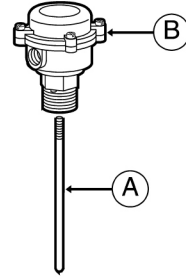

For All Remote Sensors

- b. Apply a small amount of pipe dope to the first threads (L) of the remote sensor.

WARNING

Do not use PTFE tape. Only use pipe sealant. Failure to follow these instructions will cause the probe not to function as intended and could cause property damage, personal injury or death.

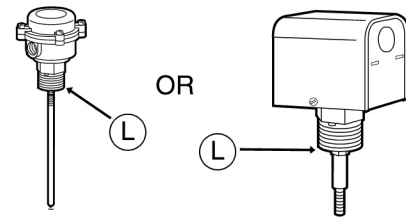

- c. Insert the remote sensor (B) into the boiler tapping (M) as determined in Step 1.

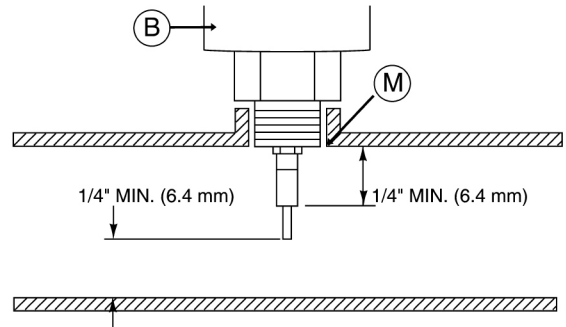

- d. Using the adjustable wrench (N), tighten the brass hex adapter (P) on the remote sensor (B) to approximately 63 ft•lb (85 N•m). DO NOT TIGHTEN BY TURNING THE SENSOR HOUSING.

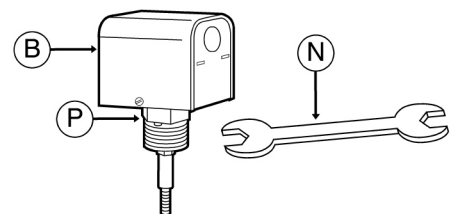

- e. Remove the sensor housing cover (Q).

1. **For Model RS-1-BR-1**, using a flathead screwdriver (R), remove the four (4) screws and separate the housing cover (Q) from the sensor (B).
2. **For Model RS-1-LP**, using a flathead screwdriver or nut driver (R), loosen the two (2) screws and separate the housing cover (Q) from the sensor (B).

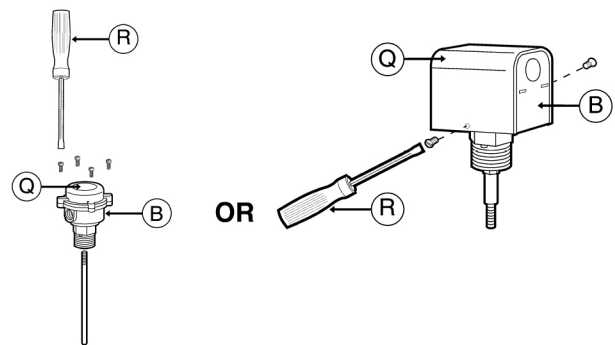

Model RS-1-BR-1

Model RS-1-LP

STEP 3 - Installing the Control Box

Mount **Control Box** in a suitable location near the boiler's main electrical panel.

NOTE

When installed as secondary LWCO on steam boilers, the boiler sight glass must be visible from the location of the control box.

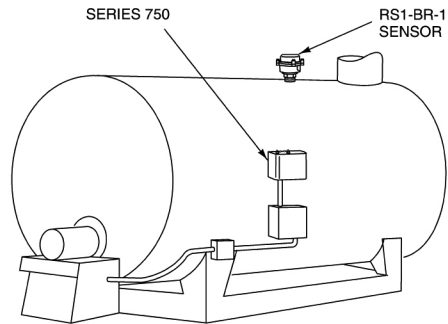

- a. Using the flatblade screwdriver or nut driver (C), loosen the two (2) screws (D) and remove cover (E).

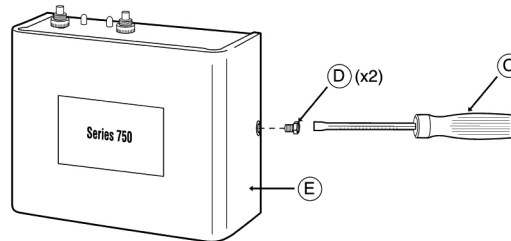

- b. Using the four (4) 3/16" (4.8mm) mounting holes (F), attach the control (G) to the boiler jacket, entry plate, or other suitable location.

NOTE: Mounting hardware is not included.

IMPORTANT: To protect control from damage caused by liquid or debris, mount as shown with buttons on top.

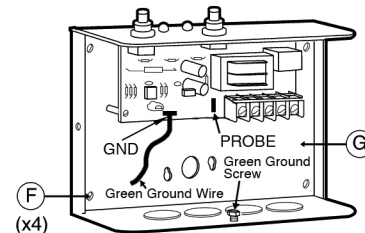

- c. Install an electrical conduit (H) to the conduit knockouts (J). Wire-ways should be able to accommodate the 120VAC supply circuit, the remote probe circuit, alarm feeder circuit and burner circuit.

- d. Connect green wire from ground screw on the controller's metal chassis to Terminal connection "GND" on PCB.

NOTE

Refer to and follow local codes and standards when selecting conduit and electrical fittings. Wires from Probe Housing and Control Box must be in their own conduit. If they are run in conduit with other wires, there may be interference that can affect the performance of the control.

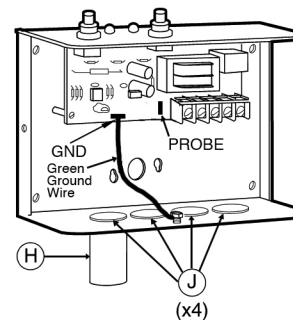

- e. Install electrical conduit between **Probe Housing** and **Control Box**.

NOTE

Wire must be 18 AWG stranded with glass braided silicone jacket (UL 3071) suitable for high temperature (200°C) service.

NOTE: Boiler sight glass must be visible from location of Control Box and must be within 25 feet of Control Body.

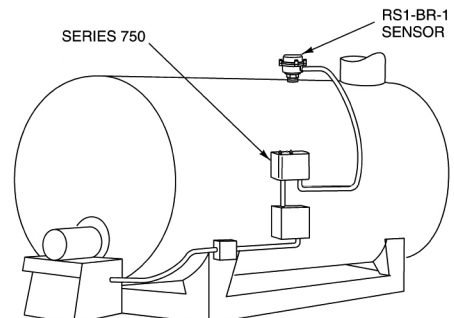

STEP 4 - Electrical Wiring

WARNING



To prevent electrical fire or equipment damage, electrical wiring must have a rating of 167°F (75°C) if the liquid's temperature exceeds 180°F (82°C). Failure to follow this warning could cause property damage, personal injury or death.

IMPORTANT

Boiler manufacturer schematics should always be followed. In the event that the boiler manufacturer's schematic does not exist, or is not available from the boiler manufacturer, refer to the schematics provided in this document.

- a. For all wire connections to the terminal block (M).
1. Strip about 1/3" (8.5 mm) of insulation from the wire.
 2. Loosen the terminal screw (N), DO NOT REMOVE, and move the wire clamping plate (P) back until the plate touches the back side of the screw head.
 3. Insert the stripped end of the wire under the wire clamping plate (P) and securely tighten the terminal screw (N).

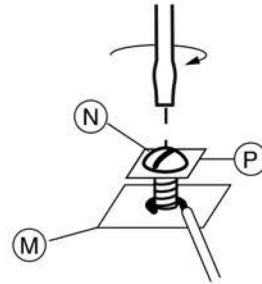

Wiring Diagram Legends

1. Bold lines indicate action to be taken in Step shown.
2. Dotted black lines indicate internal wiring.

b. Remote Sensor Wiring:

- Connect black wire from probe end to Terminal connection "PROBE" on PCB.
- Connect green wire from ground screw on the controller's metal chasis to Terminal connection "GND" on PCB.

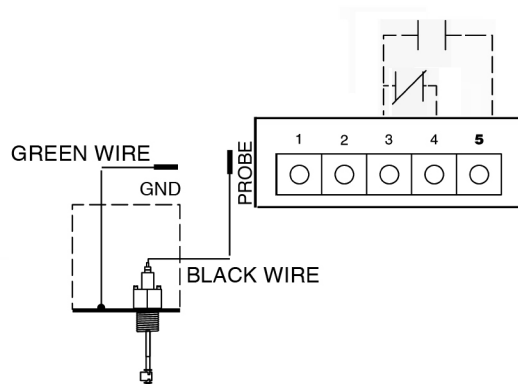

STEP 4 - Electrical Wiring

WARNING

- Electrical connections are to be made by a qualified electrician in accordance with all applicable codes, ordinance and good practices.
- The probe wire must be connected to the terminal connection marked with “Probe” from PCB and ground wire must be connected to the terminal connection marked with “GND” from PCB. Failure to follow these instructions could result in property damage, personal injury or death.

c. Control Wiring: Same voltage for control and burner circuit

- Connect hot wire to terminal 1
- Connect neutral wire to terminal 2
- Connect jumper wire from Terminal 1 to Terminal 3
- Connect a wire from Terminal 5 to the next safety device of the Burner's safety circuit, such as thermostat, gas valve, limits, etc.
- Connect wire from end of Burner circuit to Terminal 2.

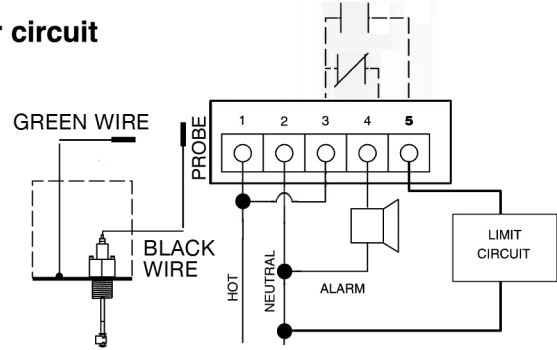

d. Control Wiring: Different voltage for control and burner circuit

- Connect hot wire to terminal 1
- Connect neutral wire to terminal 2
- Connect hot wire from the separate power supply to Terminal 3.
- Connect a wire from Terminal 5 to the next safety device in the circuit.

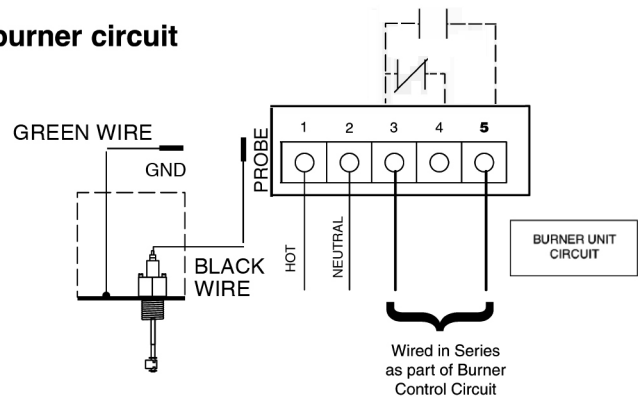

e. Secure the sensor housing cover (Q).

1. **For model RS-1-BR-1**, using the flatblade screwdriver (R), tighten the four (4) screws into the housing (Q) to approximately 3 ft•lb (4 N•m).
2. **For model RS-1-LP**, using the flatblade screwdriver or nut driver (R), tighten the two (2) screws into the housing (Q) to approximately 2 ft•lb (2.6 N•m).

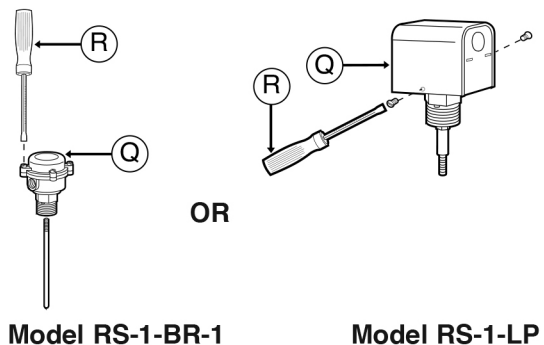

Model RS-1-BR-1

Model RS-1-LP

- f. Secure the control housing cover by using the flatblade screwdriver or nut driver (R) to tighten the two (2) screws (D) to approximately 2 ft•lb (2.6 N•m).

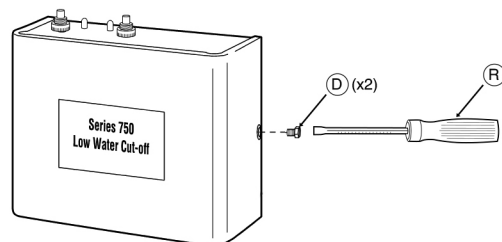

STEP 5 - Testing and Diagnostic Procedures

Series 750 LWCO with Green Power On LED and Red Low Water LED

Start-Up

- a. **Before filling the system,** turn on the electric power to the boiler.

Auto reset units:

1. Upon initial power up, Green and Red lights flash simultaneously 4 times.
2. Green and Red lights turn "ON". The burner remains "OFF".

Manual reset units:

1. Upon initial power up, Green and Red lights flash simultaneously 4 times.
2. Green turns "ON" and Red light turns "ON" after flashing continuously for another 30 seconds. The burner remains "OFF".

- b. **Now fill the boiler with water.**

Auto reset units:

1. When water touches the probe, the Green light will remain "ON".
2. The Red light will turn "OFF" and the burner will turn "ON" as long as there is water on the probe.

Manual reset units:

(When water returns to the probe, nothing will happen until the manual reset button is depressed.)

1. After depressing manual reset button, the Green and Red lights will flash simultaneously 4 times.
2. Then the Green light will turn "ON" and the Red light will turn "OFF".
3. The burner will turn "ON" as long as there is water on the probe.

Manually Testing Control

- c. **Slowly drain the boiler of water.**

Auto reset units:

1. Green LED remains "ON".
2. Red LED turns "ON".

Manual reset units:

1. When the water drops off the probe, the Green light will remain "ON".
2. The Red light starts flashing and the burner will turn "OFF", if water is off the probe.
If water returns to probe during 30 sec. Red LED will turn "OFF" and burner turns "ON".
If water below probe, Red LED turns "ON" and burner turns "OFF".

Testing Control Using "Test Button"

- d. **Depressing the test button with "water on probe"**

Auto reset units:

(Must depress and hold test button to activate test cycle.)

1. Green stays "ON", Red flash twice and turns "ON".
2. The burner will turn "OFF".
(Release test button, if water is still on probe.)
3. The Green light remains "ON".
4. Then Red light will turn "OFF".
5. The burner will turn "ON" as long as there is water on the probe.

Manual reset units:

(Must depress and hold test button for 30 sec. to activate test cycle, Red LED will flash Green LED "ON".)

1. Red LED turns "ON" and Green LED stays "ON" after test cycle is activated.
2. The burner will turn "OFF".
(Release test button. You must depress the manual reset button to unlock the low water cut-off.)
3. Then the Green light stays "ON" and the Red light will turn "OFF" after Red and Green lights flash simultaneously 4 times.
4. The burner will turn "ON" as long as there is water on the probe.

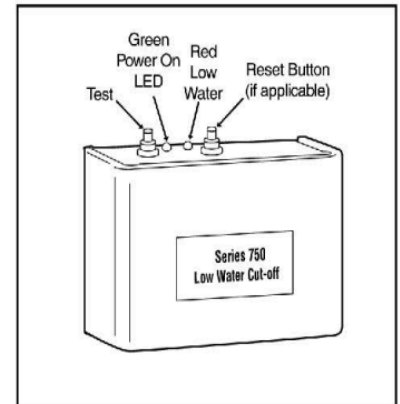

CSD-1 Compliance

On manual Reset units, if the control is in a low water condition (water off probe) when there is an interruption of power, the control will remain in a low water condition when power is restored. The reset button will need to be pressed when the water level is restored to a level above the probe.

If control fails to operate, perform the following diagnostic checks.

1. Check to be sure the water level in the boiler is at or above the level of the probe.
2. Re-check all wiring to ensure proper connections as specified in boiler manufacturers wiring diagrams or these instructions.
3. Check to ensure that PTFE tape has not been used on the threaded base of the electrode to the boiler.
4. Re-check the electrical ground connection for the remote sensor and control unit.
5. Check the quality of the boiler water to ensure adequate conductance.

MAINTENANCE

SCHEDULE:

- **Inspect probe annually or more frequently for scale build-up and clean or replace if necessary.** Make certain there is no scale or build-up on the probe or it's white PFA insulator. Be careful not to damage the PFA insulator.
- **Test the low water cut-off annually or more frequently, if required by code.**

WARNING

- Regular maintenance is required. Failure to follow the device maintenance could result in property damage, personal injury or death.

CAUTION

Replace Probe if:

- PFA insulator is cracked or worn.
- Probe is loose.

Failure to follow this caution could cause property damage, personal injury or death.

- **Replace probe every 10 years.** More frequent replacement of the probe is required if it is used in locales where significant water treatment is required, or in applications with high make-up water requirements
- **Replace the low water cut-off every 15 years.**

NOTE

Clean probe by wiping with non-abrasive cloth and rinsing with clean water. **DO NOT** use sharp instruments to remove any accumulations of rust or scale.

COMMERCIAL WARRANTY

Warranty. For goods sold to commercial buyers, Seller warrants the goods sold to Buyer hereunder (with the exception of membranes, seals, gaskets, elastomer materials, coatings and other “wear parts” or consumables all of which are not warranted except as otherwise provided in the quotation or sales form) will be (i) be built in accordance with the specifications referred to in the quotation or sales form, if such specifications are expressly made a part of this Agreement, and (ii) free from defects in material and workmanship for a period of one (1) year from the date of installation or two (2) years from the date of manufacture, whichever shall occur first, unless a longer period is specified in the product documentation (the “Warranty”).

Except as otherwise required by law, Seller shall, at its option and at no cost to Buyer, either repair or replace any product which fails to conform with the Warranty provided Buyer gives written notice to Seller of any defects in material or workmanship within ten (10) days of the date when any defects or non-conformance are first manifest. Under either repair or replacement option, Seller shall not be obligated to remove or pay for the removal of the defective product or install or pay for the installation of the replaced or repaired product and Buyer shall be responsible for all other costs, including, but not limited to, service costs, shipping fees and expenses. Seller shall have sole discretion as to the method or means of repair or replacement. Buyer’s failure to comply with Seller’s repair or replacement directions shall terminate Seller’s obligations under this Warranty and render the Warranty void. Any parts repaired or replaced under the Warranty are warranted only for the balance of the warranty period on the parts that were repaired or replaced. Seller shall have no warranty obligations to Buyer with respect to any product or parts of a product that have been: (a) repaired by third parties other than Seller or without Seller’s written approval; (b) subject to misuse, misapplication, neglect, alteration, accident, or physical damage; (c) used in a manner contrary to Seller’s instructions for installation, operation and maintenance; (d) damaged from ordinary wear and tear, corrosion, or chemical attack; (e) damaged due to abnormal conditions, vibration, failure to properly prime, or operation without flow; (f) damaged due to a defective power supply or improper electrical protection; or (g) damaged resulting from the use of accessory equipment not sold or approved by Seller. In any case of products not manufactured by Seller, there is no warranty from Seller; however, Seller will extend to Buyer any warranty received from Seller’s supplier of such products.

THE FOREGOING WARRANTY IS EXCLUSIVE AND IN LIEU OF ANY AND ALL OTHER EXPRESS OR IMPLIED WARRANTIES, GUARANTEES, CONDITIONS OR TERMS OF WHATEVER NATURE RELATING TO THE GOODS PROVIDED HEREUNDER, INCLUDING WITHOUT LIMITATION ANY IMPLIED WARRANTIES OF MERCHANTABILITY AND FITNESS FOR A PARTICULAR PURPOSE, WHICH ARE HEREBY EXPRESSLY DISCLAIMED AND EXCLUDED. EXCEPT AS OTHERWISE REQUIRED BY LAW, BUYER’S EXCLUSIVE REMEDY AND SELLER’S AGGREGATE LIABILITY FOR BREACH OF ANY OF THE FOREGOING WARRANTIES ARE LIMITED TO REPAIRING OR REPLACING THE PRODUCT AND SHALL IN ALL CASES BE LIMITED TO THE AMOUNT PAID BY THE BUYER FOR THE DEFECTIVE PRODUCT. IN NO EVENT SHALL SELLER BE LIABLE FOR ANY OTHER FORM OF DAMAGES, WHETHER DIRECT, INDIRECT, LIQUIDATED, INCIDENTAL, CONSEQUENTIAL, PUNITIVE, EXEMPLARY OR SPECIAL DAMAGES, INCLUDING BUT NOT LIMITED TO LOSS OF PROFIT, LOSS OF ANTICIPATED SAVINGS OR REVENUE, LOSS OF INCOME, LOSS OF BUSINESS, LOSS OF PRODUCTION, LOSS OF OPPORTUNITY OR LOSS OF REPUTATION.

LIMITED CONSUMER WARRANTY

Warranty. For goods sold for personal, family or household purposes, Seller warrants the goods purchased hereunder (with the exception of membranes, seals, gaskets, elastomer materials, coatings and other “wear parts” or consumables all of which are not warranted except as otherwise provided in the quotation or sales form) will be free from defects in material and workmanship for a period of one (1) year from the date of installation or two (2) years from the product date code, whichever shall occur first, unless a longer period is provided by law or is specified in the product documentation (the “Warranty”).

Except as otherwise required by law, Seller shall, at its option and at no cost to Buyer, either repair or replace any product which fails to conform with the Warranty provided Buyer gives written notice to Seller of any defects in material or workmanship within ten (10) days of the date when any defects or non-conformance are first manifest. Under either repair or replacement option, Seller shall not be obligated to remove or pay for the removal of the defective product or install or pay for the installation of the replaced or repaired product and Buyer shall be responsible for all other costs, including, but not limited to, service costs, shipping fees and expenses. Seller shall have sole discretion as to the method or means of repair or replacement. Buyer's failure to comply with Seller's repair or replacement directions shall terminate Seller's obligations under this Warranty and render this Warranty void. Any parts repaired or replaced under the Warranty are warranted only for the balance of the warranty period on the parts that were repaired or replaced. The Warranty is conditioned on Buyer giving written notice to Seller of any defects in material or workmanship of warranted goods within ten (10) days of the date when any defects are first manifest.

Seller shall have no warranty obligations to Buyer with respect to any product or parts of a product that have been: (a) repaired by third parties other than Seller or without Seller's written approval; (b) subject to misuse, misapplication, neglect, alteration, accident, or physical damage; (c) used in a manner contrary to Seller's instructions for installation, operation and maintenance; (d) damaged from ordinary wear and tear, corrosion, or chemical attack; (e) damaged due to abnormal conditions, vibration, failure to properly prime, or operation without flow; (f) damaged due to a defective power supply or improper electrical protection; or (g) damaged resulting from the use of accessory equipment not sold or approved by Seller. In any case of products not manufactured by Seller, there is no warranty from Seller; however, Seller will extend to Buyer any warranty received from Seller's supplier of such products.

THE FOREGOING WARRANTY IS PROVIDED IN PLACE OF ALL OTHER EXPRESS WARRANTIES. ALL IMPLIED WARRANTIES, INCLUDING BUT NOT LIMITED TO THE IMPLIED WARRANTIES OF MERCHANTABILITY AND FITNESS FOR A PARTICULAR PURPOSE, ARE LIMITED TO ONE (1) YEAR FROM THE DATE OF INSTALLATION OR TWO (2) YEARS FROM THE PRODUCT DATE CODE, WHICHEVER SHALL OCCUR FIRST. EXCEPT AS OTHERWISE REQUIRED BY LAW, BUYER'S EXCLUSIVE REMEDY AND SELLER'S AGGREGATE LIABILITY FOR BREACH OF ANY OF THE FOREGOING WARRANTIES ARE LIMITED TO REPAIRING OR REPLACING THE PRODUCT AND SHALL IN ALL CASES BE LIMITED TO THE AMOUNT PAID BY THE BUYER FOR THE DEFECTIVE PRODUCT. IN NO EVENT SHALL SELLER BE LIABLE FOR ANY OTHER FORM OF DAMAGES, WHETHER DIRECT, INDIRECT, LIQUIDATED, INCIDENTAL, CONSEQUENTIAL, PUNITIVE, EXEMPLARY OR SPECIAL DAMAGES, INCLUDING BUT NOT LIMITED TO LOSS OF PROFIT, LOSS OF ANTICIPATED SAVINGS OR REVENUE, LOSS OF INCOME, LOSS OF BUSINESS, LOSS OF PRODUCTION, LOSS OF OPPORTUNITY OR LOSS OF REPUTATION.

Some states do not allow limitations on how long an implied warranty lasts, so the above limitation may not apply to you. Some states do not allow the exclusion or limitation of incidental or consequential damages, so the above exclusions may not apply to you. This warranty gives you specific legal rights, and you may also have other rights which may vary from state to state.

To make a warranty claim, check first with the dealer from whom you purchased the product or call +1-847-966-3700 for the name and location of the nearest dealer providing warranty service.

Xylem |'zīləm|

- 1) The tissue in plants that brings water upward from the roots;
- 2) a leading global water technology company.

We're a global team unified in a common purpose: creating advanced technology solutions to the world's water challenges. Developing new technologies that will improve the way water is used, conserved, and re-used in the future is central to our work. Our products and services move, treat, analyze, monitor and return water to the environment, in public utility, industrial, residential and commercial building services, and agricultural settings. With its October 2016 acquisition of Sensus, Xylem added smart metering, network technologies and advanced data analytics for water, gas and electric utilities to its portfolio of solutions. In more than 150 countries, we have strong, long-standing relationships with customers who know us for our powerful combination of leading product brands and applications expertise with a strong focus on developing comprehensive, sustainable solutions.

For more information on how Xylem can help you, go to www.xylem.com



Xylem Inc.
8200 N. Austin Avenue
Morton Grove, Illinois 60053
Phone: (847) 966-3700
Fax: (847) 965-8379
www.mcdonnellmiller.com

McDonnell & Miller is a trademark of Xylem Inc. or one of its subsidiaries.
© 2017 Xylem Inc. MM-213N April 2017 Part No. 210210

