

C437D,E,F,G,H,J,K and C637B Gas Pressure Switches

PRODUCT DATA



GENERAL

The C437 and C637 Gas Pressure Switches are pressure-actuated switching devices used in industrial gas system applications for safety shutoff, pressure control, and differential-pressure control.

FEATURES

- C437 models have direct- and reverse-acting (spst) switching; C637B has single-pole, double-throw (spdt) switching.
- Pressure ranges: 1/2 to 5-1/2 in. of water (10 to 140 mm of water, or 0.1 to 1.4 kPa); 1 to 26 in. of water (50 to 700 mm of water, or 0.5 to 7 kPa); 1/2 to 5 psi (300 to 3500 mm of water, or 3 to 35 kPa); 1 to 10 psi (500 to 7000 mm of water, or 5 to 70 kPa).
- Models intended for lockout applications must be manually reset before resuming operation.
- Trip-free mechanism on manual reset models ensures that the limit function of the switch cannot be defeated by jamming the reset lever.
- External manual reset button on side of lockout models.
- Enclosed setting impedes tampering and provides dust-resistant operation.
- Buna-N fiber-reinforced material for increased strength of control diaphragm.
- Two Buna-N fiber-reinforced seal-off diaphragms for added reliability.
- Clear glass cover allows observation of interior mechanism to aid setting and checkout.
- Mercury switch provides visual indication of switch position.
- Heavy die-cast case increases durability and resistance to corrosion.
- Main control diaphragm completely enclosed a leak-proof chamber can be vented to a safe area.
- Models with a pressure range of 1 to 26 in. of water (50 to 700 mm of water, or 0.5 to 7 kPa) have a restrictive orifice in the inlet pressure channel to compensate for momentary surges in gas pressure.
- Field-addable orifices of various sizes are available.
- Models available with rainproof, dustproof, sleet- and ice-resistant enclosure; meets NEMA 3R specification.

Contents

| | |
|----------------------------|---|
| General | 1 |
| Features | 1 |
| Specifications | 2 |
| Ordering Information | 2 |
| Recycling Notice | 4 |
| Installation | 4 |
| Setting and Checkout | 6 |



SPECIFICATIONS

Models:

| Model Number | Switch Action (Response at Setpoint to Pressure Change) | Manual Reset ^a (Locks Out on Switch Break) |
|--------------------|--|--|
| C437D | spst, breaks on rise | yes |
| C437E | spst, breaks on fall | yes |
| C437F ^b | 2 spst circuits ^c , breaks one, makes one | no |
| C437G ^a | spst, breaks on rise | no |
| C437H ^a | spst, breaks on fall | no |
| C437J | 2 spst circuits ^c , breaks one, makes one | yes (lockout on rise) |
| C437K | 2 spst circuits ^c , breaks one, makes one | yes (lockout on fall) |
| C637B | spst, breaks R-W and makes R-B on fall | no |

^a Designated Manual Reset 2; the trip-free reset mechanism does not permit the switch to function as an automatic-reset device when the manual reset lever is held in the Reset position.

^b Weatherproof enclosure (NEMA 3R) available.

^c Two separate switches are contained in the same mercury bulb.

Switch Ratings (In Amperes):

| Voltage | C437E,G and H | | | C437F,J,K | | |
|---------|---------------|--------------|----------------|-----------|--------------|----------------|
| | Full Load | Locked Rotor | Resistive Load | Full Load | Locked Rotor | Resistive Load |
| 120 Vac | 8.0 | 48.0 | 10.0 | 8.0 | 48.0 | 10.0 |
| 240 Vac | 5.1 | 30.6 | 5.0 | 5.1 | 30.6 | 5.0 |
| 120 Vdc | 2.4 | 24.0 | 5.0 | 2.0 | 20.0 | 8.0 |
| 240 Vdc | 1.2 | 12.0 | 2.0 | 1.0 | 10.0 | 3.0 |

C637B—62.5 VA at 120 and 240 Vac, pilot duty.

ORDERING INFORMATION

When purchasing replacement and modernization products from your TRADELINE® wholesaler or your distributor, refer to the TRADELINE® Catalog or price sheets for complete ordering number, or specify—

1. Order number.
2. Pressure range.
3. Replacement parts, if desired.
4. Accessories, if desired.

If you have additional questions, need further information, or would like to comment on our products or services, please write or phone:

1. Your local Honeywell Home and Building Control Division Sales Office (check white pages of phone directory).
2. Home and Building Control Division Customer Logistics
Honeywell Inc., 1985 Douglas Drive North
Minneapolis, Minnesota 55422-4386

In Canada—Honeywell Limited/Honeywell Limitée, 35 Dynamic Drive, Scarborough, Ontario M1V 4Z9. International Sales and Service offices in all principal cities of the world. Manufacturing in Australia, Canada, Finland, France, Germany, Japan, Mexico, Netherlands, Spain, Taiwan, United Kingdom, U.S.A.

Switch:

Mercury switch (C437F,J and K have two spst switches in one mercury bulb).

Differentials:

Fixed, nominal; measured at pressure indicated:

| Model Numbers | Pressure Range ^a | | | | | | | | | | | | Type ^a |
|---------------|---|------------------|-------------------|--|------|------|--|-----|------|---|------------------|-------------------|--------------------------|
| | 1/2 to 5-1/2 in. (10-140 mm, or 0.1-1.4 kPa) Differential Measured at 1/2 in. | | | 1 to 26 in. ^b (50-700 mm, or 0.5-7 kPa) differential measured at 15 in. | | | 1/2 to 5 psi (300-3500 mm, or 3-35 kPa) differential measurement at midscale | | | 1 to 10 psi (500-7000 mm, or 5-70 kPa) differential measurement | | | |
| | in. | mm | kPa | in. | mm | kPa | psi | mm | kPa | psi | mm | kPa | |
| C437D,J | — | — | — | 1-3/4 | 44.5 | 0.44 | 1/2 | 352 | 3.45 | 1 ^c | 703 ^c | 6.89 ^c | Subtractive ^d |
| C437E,F,H,K | 0.25 ^e | 6.4 ^e | 0.06 ^e | 1-1/4 | 31.8 | 0.31 | 1/4 | 176 | 1.72 | 1/2 ^e | 352 ^e | 3.45 ^e | Additive ^f |
| C637B | 0.15 | 3.8 | 0.04 | | | | | | | | | | |
| C437G | — | — | — | 1-1/4 | 31.8 | 0.31 | 1/4 | 176 | 1.72 | 1/2 | 352 | 3.45 | Subtractive |

^a in. = inches of water; mm = millimeters of water.

^b Restrictive orifice in inlet pressure channel to compensate for momentary surges in gas pressure.

^c Not available for C437J.

^d Subtractive models: switching action occurs on pressure rise to the setpoint.

^e Not available for C437K.

^f Additive models: switching action occurs on pressure fall to the setpoint.

Pressure Ranges (Scale Range):

Specify one:

- 1/2 to 5-1/2 inches of water (10 to 140 mm of water, or 0.1 to 1.4 kPa).
- 1 to 26 inches of water (50 to 700 mm of water, or 0.5 to 7 kPa).
- 1/2 to 5 lb per sq in. (300 to 3500 mm of water, or 3 to 35 kPa).
- 1 to 10 lb per sq in. (500 to 7000 mm of water, or 5 to 70 kPa).

Maximum Sustained Operating Pressure:

| Pressure Range | Maximum Pressure | |
|---------------------------|------------------|-------|
| | psi | kPa |
| 1/2 to 5-1/2 in. of water | 3.0 | 20.7 |
| 1 to 26 in. of water | 5.0 | 34.5 |
| 1/2 to 5 psi | 15.0 | 103.4 |
| 1 to 10 psi | 30.0 | 206.8 |

Pipe Connections:

- Main or High Pressure: 1/2 in. NPT, female.
- Vent or Low Pressure: 1/8 in. NPT, female.
- Electrical Wiring: Hole tapped for 1/2 in. conduit.

Maximum Ambient Temperature:

125°F (52°C).

Minimum Temperature:

32°F (0°C).

Approvals:

- Underwriters Laboratories Inc. Listed: File No. MP2168, Guide No. MFHX.
- Canadian Standards Association Certified: File No. 1620, Guide No. 380-W-1.16.
- Factory Mutual Approved: Report No. 13031-S5 and 19291.

Replacement Parts:

- 106729 Cover Glass, 6 in. (152.4 mm) diameter.
- 139870A Cover Glass, for rainproof enclosures.
- 106747 Cover Retaining Ring, for models manufactured before 1973.
- 118733-21 Retaining Clip, for models manufactured since 1975.

Accessories:

- 4074BWK Bag Assembly: Contains two 137755 Mounting Brackets and four self-tapping screws: for surface mounting (standard on C437G and H). Mounting brackets are shown by dashed lines in Fig. 1.

Field-addable Orifices:

- 124674: 0.011 in. (0.28 mm) diameter.
- 122160: 0.018 in. (0.46 mm) diameter.

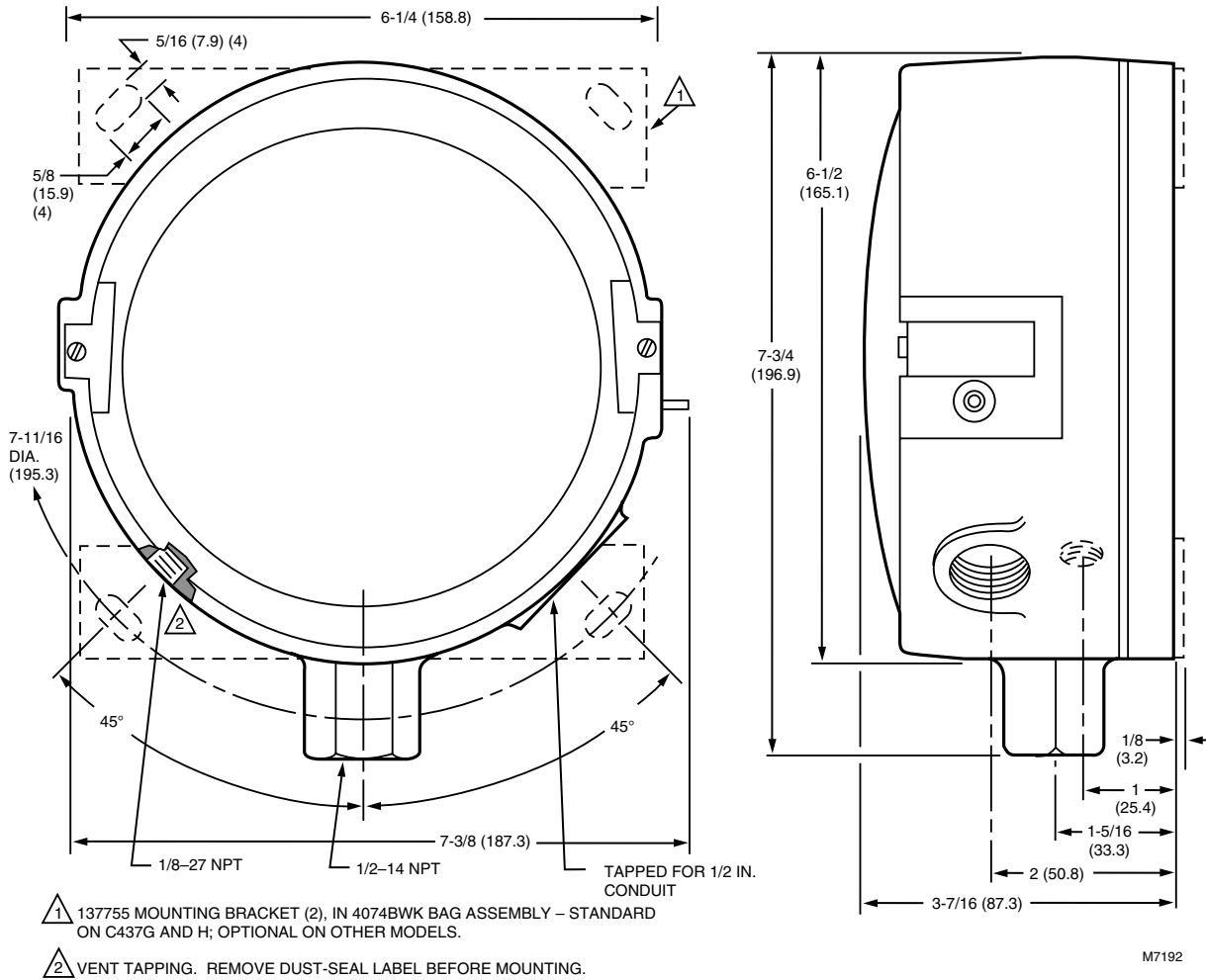

Fig. 1. Installation dimensions of the C437 and C637 gas pressure switches, in in. (mm).



RECYCLING NOTICE

This control contains mercury in a sealed tube. Do *not* place control in the trash at the end of its useful life.

If this control is replacing a control that contains mercury in a sealed tube, do *not* place your old control in the trash.

Contact your local waste management authority for instructions regarding recycling and the proper disposal of this control, or of an old control containing mercury in a sealed tube.

INSTALLATION

When Installing this Product...

- 1 Read these instructions carefully. Failure to follow them could damage the product or cause a hazardous condition.
- 2 Check the ratings given in the instructions and on the product to make sure the product is suitable for your application.
- 3 Installer must be a trained, experienced, flame safeguard control technician.
- 4 After installation is complete, check out product operation as provided in these instructions.

CAUTION

Disconnect all power to the pressure switch before beginning installation to prevent electrical shock and equipment damage.

IMPORTANT

1. Remove the dust-seal label from the vent tapping before mounting.
2. Accurately level the pressure switch for proper operation.
3. The C637B pressure switch is a low differential device. Mount it in a vibration-free location to prevent chattering.
4. Do not hand tighten the pressure switch by holding the case.

Follow local codes or ordinances *in all cases* when different from these recommendations.

Fig. 1 shows the mounting dimensions for the C437 and C637 models, and for the accessory mounting bracket (standard on C437G and H). See Fig. 2 for the individual components.

Location

Mount the gas pressure switch downstream from the pressure regulator. Mount low gas pressure switches upstream of any shutoff valve. Mount high gas pressure switches just upstream from the burner. When pipe mounting, locate the device on the portion of the pipe that is most level because the mercury switch requires level orientation. See step 4 in the Mounting section.

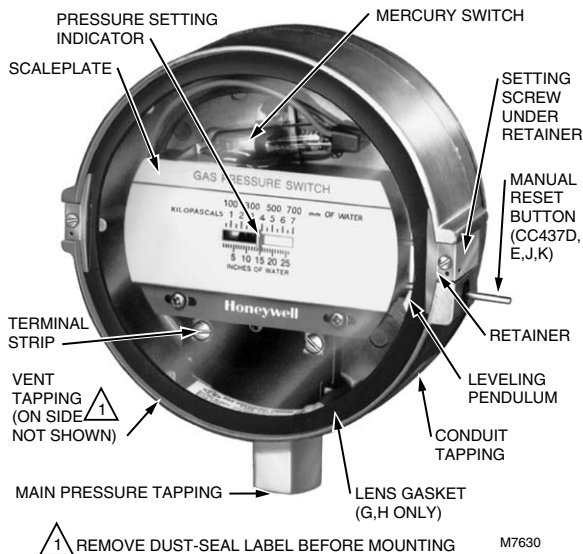

Fig. 2. Principal parts of the gas pressure switch.

Mounting

- 1 Remove the dust-seal label from the vent tapping.
- 2 Remove the screws and retainers, and the cover glass.
- 3 Mount the device on the pipe or nearby vertical surface.

Use nipple and T for pipe mounting or the mounting bracket for surface mounting. If a mounting bracket is used, install the bracket before making piping connections (standard on C437G and H). Mount the bracket horizontally with the four 10-24 flathead tapping screws provided.

- 4 Level the device carefully.
 - a. Level the device so that the point of leveling pendulum is aligned with the mark on the inside of the case.
 - b. When pipe mounting, install the device at right angles to the pipe so that it can be leveled by additional tightening of the pipe fittings.
 - c. The surface mounting bracket has elongated holes that allow limited leveling after the mounting screws are started.
 - d. Accurate leveling is most essential at very low pressure settings.
 - e. If necessary, make arrangements to hold pipe-mounted units steady and level with bracing.

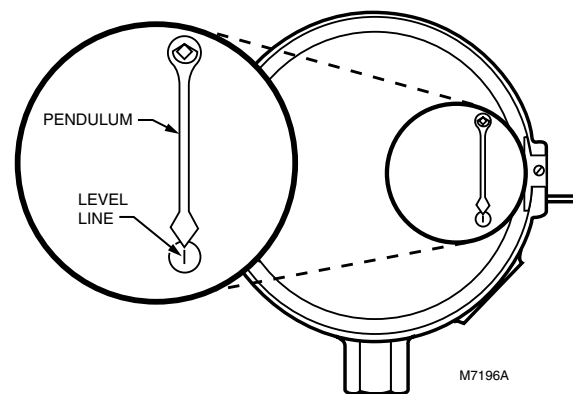

Fig. 3. Properly leveled C437/637.

IMPORTANT

To avoid leaks and case damage, use a parallel jaw wrench on the hexagonal part of the case close to the pipe. Carefully make all connections and test for leakage. Do not tighten the pressure switch by holding the case.

- 5 Complete the main piping.
- 6 Connect the piping to the pressure switch. Select the application from the following, and proceed as instructed.
 - a. Hazardous-gas applications: Install a 1/8 in. NPT pipe at the vent tapping on all hazardous-gas applications.

WARNING

The vent must be installed so that any gas leakage is vented into a safe place in event of a diaphragm failure.

- b. Differential-pressure applications:

- (1) Connect the high-pressure side of the system to the 1/2 in. NPT main pressure tapping on the gas pressure switch.
- (2) Connect the low pressure side to the 1/8 in. NPT vent tapping.

⚠ WARNING

No venting is possible in this case. Do not use this device for differential pressure control with the hazardous gases.

- c. Negative-pressure applications: Connect the low pressure side to the 1/8 in. NPT vent tapping.

⚠ WARNING

This application is for use only with nonhazardous gases. Do not use this device for negative-pressure applications with hazardous gases.

- 7 Install other controls in the system. Connect wiring, and complete setting and checkout before replacing the cover glass and retainers. See Setting and Checkout section.

Wiring

⚠ CAUTION

1. Disconnect all power to the pressure switch before connecting wiring to prevent electrical shock and equipment damage.
2. When using a C437F,J, or K, both ends of the switch (W-R and B-R) must be used at the same voltage in the same branch circuit.

All wiring must comply with local electrical codes, ordinances, and regulations. Do not exceed the switch ratings given in the Specifications section.

Wiring diagrams for the different models are shown in Fig. 4, 5 and 6. The switches make or break as indicated in the diagrams. Connect the wiring to the screw terminals on the terminal strip after removing the cover glass. Route the wires through the conduit tapping.

C437D,G: BREAKS ON PRESSURE RISE
C437E,H: BREAKS ON PRESSURE FALL

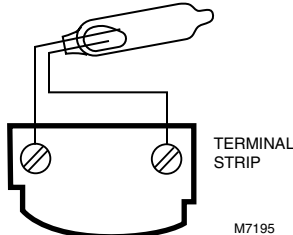
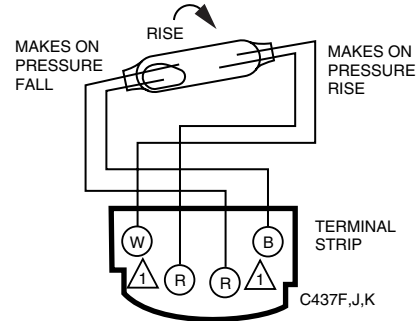

Fig. 4. Wiring diagram for C437D,E,G,H.



⚠ BOTH ENDS OF THE SWITCH (W-R AND B-R) MUST BE USED AT THE SAME VOLTAGE IN THE SAME BRANCH CIRCUIT.

Fig. 5. Wiring diagram for C437F,J,K.

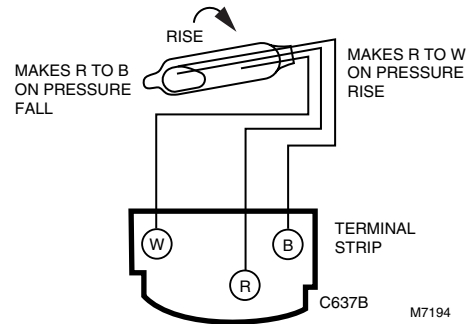

Fig. 6. Wiring diagram for C637B.

SETTING AND CHECKOUT

Setting

In the C437D,G and J models, the differential is *subtractive*. The *upper* operating point is determined by the *setpoint*, while the *lower* operating point is determined by the setpoint *minus* the differential. In the C437E,F,H,K and C637B models, the differential is *additive*. The *lower* operating point is determined by the *setpoint*, while the *upper* operating point is determined by the setpoint *plus* the differential. Operating points are shown in Fig. 7.

Remove the retainer and adjust the *setpoint* for the desired operating pressure (cutout pressure on a C437D,E,G, or H spst model) by turning the setting screw (Fig. 2) clockwise to increase the setpoint and counterclockwise to decrease it.

Trip-Free Manual Reset Feature (C437D,E,J and K only)

The C437D breaks and the C437J breaks R-B and makes R-W when the pressure rises to the setpoint. The C437E breaks, and the C437K breaks R-W and makes R-B when the pressure falls to the setpoint. None of these pressure switches will automatically return to their former positions.

To reset one of these pressure switches, wait until the pressure *falls* to the setpoint minus the differential (C437D or J), or *rises* to the setpoint plus the differential (C437E or K). Then depress the manual reset button (Fig. 2) and release it. *The pressure switch will not be reset until you release the manual reset button.* This prevents the switch from becoming an automatic-reset device if the reset button is stuck, held in, or tied down.

Checkout

Adjust the setpoint for normal operation and check to see that the gas pressure switch performs as intended. Use a manometer or accurate pressure gauge connected upstream from the switch to measure the actual pressure.

The most likely cause of inaccurate operation is off-level mounting. Refer to step 4 in the Mounting section and correct any installation that does not check out satisfactorily.

C437D,G or J (Subtractive Differential)

- 1 Put the system into normal operation, and set the pressure switch at the normal setpoint (above the normal operating pressure).
- 2 Turn the setting screw (Fig. 2) slowly toward a lower pressure setting (counterclockwise ↺) to simulate a pressure increase.
- 3 When the setpoint is approximately equal to the pressure indicated on the pressure gauge, the C437D or G should break contact and turn off the controlled equipment; the C437J should break R to B and make R to W.
- 4 The C437D or J should lock out.

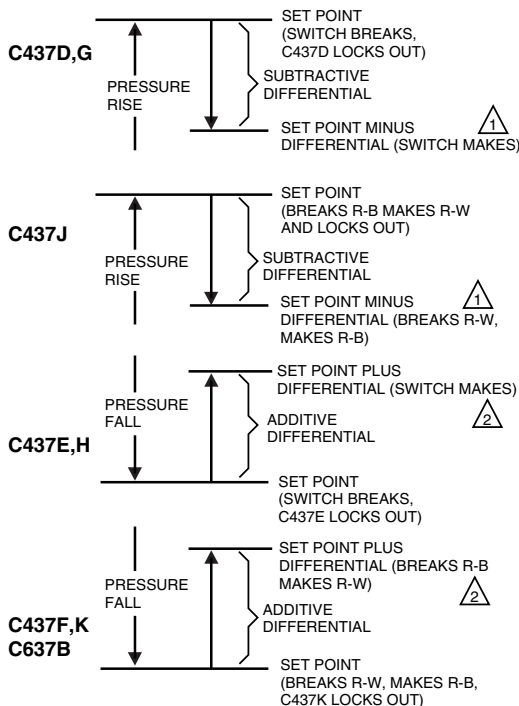

- 1 C437D AND J ARE MANUAL RESET MODELS; THEY CAN BE MANUALLY RESET WHEN THE PRESSURE FALLS TO THE SET POINT MINUS THE DIFFERENTIAL.
- 2 C437E AND K ARE MANUAL RESET MODELS; THEY CAN BE MANUALLY RESET WHEN THE PRESSURE RISES TO THE SET POINT PLUS THE DIFFERENTIAL.
- M7197

Fig. 7. C437 and C637 operating points.

- 5 Turn the setting screw toward a high pressure setting (clockwise ↻) to simulate a pressure decrease *greater than the differential*. The C437G should make contact and turn on the controlled equipment.
- 6 Push the manual reset button (Fig. 2) on the C437D or J; the C437D should make, and the C437J should break R to W and make R to B.

C437E,F,H,K or C637B (Additive Differential)

- 1 Put the system into normal operation and gradually close the upstream gas shutoff valve to cause a pressure decrease.
- 2 When the pressure gauge indicates that the pressure is approximately equal to the setpoint, the C437E or H should break contact and turn off the controlled equipment; the C437F,K or C637B should break R to W and make R to B.
- 3 The C437E or K should lock out.
- 4 Open the gas shutoff valve to increase the pressure again. When the pressure rises to the setpoint *plus the differential*, the C437H should make contact and turn on the controlled equipment; the C437F or C637B should break R to B and make R to W.
- 5 Push the manual reset button (Fig. 2) on the C437E or K; the C437E should make, and the C437K should break R to B and make R to W.

Completing the Installation

- 1 Remove the pressure gauge or manometer used for testing. Visually recheck the piping, wiring, and setting.
- 2 Replace the cover glass and retainers.
- 3 Return the system pressure to normal.
- 4 Push the manual reset button (C437D,E,J or K only).

Installing a Pressure Orifice (Fig. 8)

To compensate for momentary surges in gas pressure, install a restrictive orifice in the inlet pressure channel of the pressure switch. (Refer to Accessories in the Specification section for the orifice sizes available.)

Align pressure orifice into reset located inside of the main pressure tapping at the bottom. Press orifice into place using 1/8 in. dowel rod.

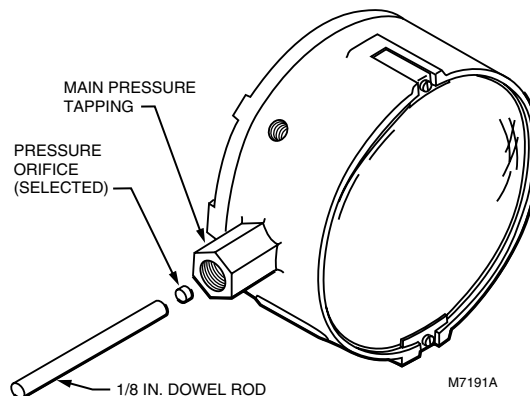

Fig. 8. Installing a pressure orifice to compensate for pressure surges.

Honeywell

Automation and Control Solutions

Honeywell International Inc. Honeywell Limited—Honeywell Limitée
1985 Douglas Drive North 35 Dynamic Drive
Golden Valley, MN 55422 Scarborough, Ontario M1V 4Z9

