

Type HSR Pressure Reducing Regulator for Residential, Commercial, or Industrial Applications



TYPE HSR ANGLE BODY

- High Capacity

- Compact Design

- High Capacity Internal Relief

- Globe Bodies

- Angle Bodies

- Fixed Factor / PFM Accuracy

- Meets or Exceeds ANSI B109.4 / CGA 6.18 Requirements

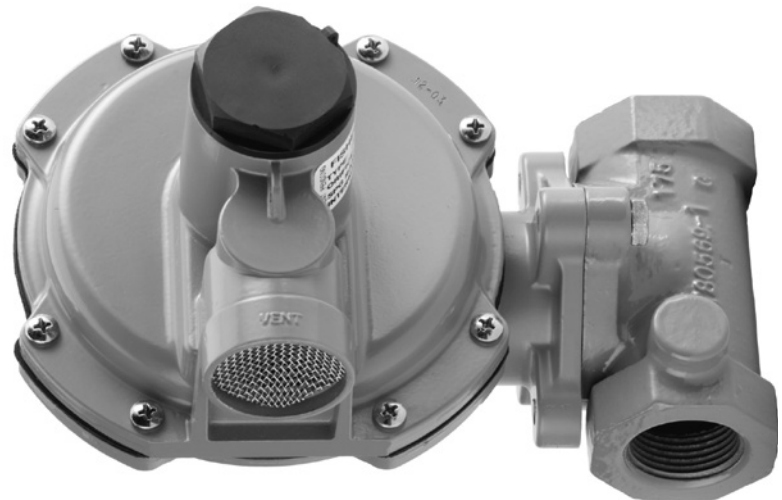

TYPE HSR GLOBE BODY



www.fisherregulators.com



Bulletin 71.1:HSR

Specifications

The Specifications section lists specifications for Type HSR Pressure Reducing Regulators. Specifications for a given regulator as it originally comes from the factory are stamped on the spring case nameplate.

Body Sizes (Inlet x Outlet) and End Connection Styles

3/4, 3/4 x 1, and 1 NPT
All sizes are available in Globe or Angle body.

Allowable Inlet Pressures⁽¹⁾

Emergency: 150 psig / 10.3 bar
Maximum Operating Pressure: See Table 1

Allowable Outlet Pressures⁽¹⁾

Emergency (Casing): 25 psig / 1.7 bar
Maximum Operating Pressure to Avoid Internal Parts Damage: 3 psi / 0.21 bar differential above outlet pressure setting

Outlet Pressure Ranges

See Table 2

Orifice Sizes

See Table 1

Typical Regulating Capacities

3/4 NPT Globe: See Table 8
3/4 x 1 NPT Globe: See Table 9
1 NPT Globe: See Table 10
3/4 NPT Angle: See Table 11
3/4 x 1 NPT Angle: See Table 12
1 NPT Angle: See Table 13
1% Pressure Factor Accuracy: See Tables 6 and 7

Flow and Sizing Coefficients

See Table 4

Internal Relief Performance

Approximate Internal Relief Start-To-Discharge Point: 6 to 12-inches w.c. / 15 to 30 mbar above outlet pressure setting (Applies to 6 to 8-inches w.c. / 15 to 20 mbar and 8 to 10-inches w.c. / 20 to 25 mbar springs only)
Relief Performance: See Figures 3 and 4, and Table 14

Temperature Capabilities

-20 to 160°F / -29 to 71°C

Pressure Setting Adjustment

Adjusting Screw

Pressure Registration

Internal

Lockup Performance During Normal Operation

ORIFICE SIZE		LOCKUP ABOVE SETPOINT		LOCKUP ABOVE SETPOINT	
Inches	mm	Inches w.c.	mbar	psi	mbar
1/8	3.2	1	2	0.15	10.3
3/16	4.8	1	2	0.15	10.3
1/4	6.4	2	5	0.15	10.3
3/8	9.5	2.5	6	0.15	10.3
1/2	13	3	7	0.15	10.3

Spring Case Vent Connection

Standard: 1 NPT with removable screen
Optional: 3/4 NPT with removable screen

Construction Materials

Body: Cast iron
Body Gasket: Nitrile (NBR)
Closing Cap: ASA thermoplastic (provides UV-ray protection)
Adjusting Screw: Delrin®
Diaphragm Case, Spring Case, Diaphragm Plate, Orifice, and Valve Stem: Aluminum
Pusher Post or Relief Valve Seat: Delrin®
Diaphragm and Disk: Nitrile (NBR)
Control Spring: Zinc-plated steel
Relief Valve Spring: Stainless steel
Relief Valve Spring Retainer: Stainless steel
Vent Screen: Stainless steel
Lever Pin: Stainless steel
Spring Seat, Lever, and Other Metal Parts: Plated steel

Body Vent Mounting Positions

See Figure 5

Approximate Weight

4 pounds / 2 kg

Designed, Tested, and Evaluated Consistent With:

ANSI B109.4 / CGA 6.18

1. The pressure/temperature limits in this Bulletin and any applicable standard or code limitation should not be exceeded. Delrin® is a mark owned by E.I. du Pont de Nemours and Co.

Introduction

The Type HSR direct-operated, spring-loaded regulators provide economical pressure reducing control in a variety of residential, commercial, and industrial applications. These regulators can be used with natural, manufactured, or liquefied petroleum gases and have the same inlet and outlet pressure capabilities.

In addition, the Type HSR regulators have internal relief across the diaphragm to help minimize overpressure. Any outlet pressure above the start-to-discharge point of the nonadjustable relief valve spring moves the diaphragm off the relief valve seat, allowing excess pressure to bleed out through the screened spring case vent.

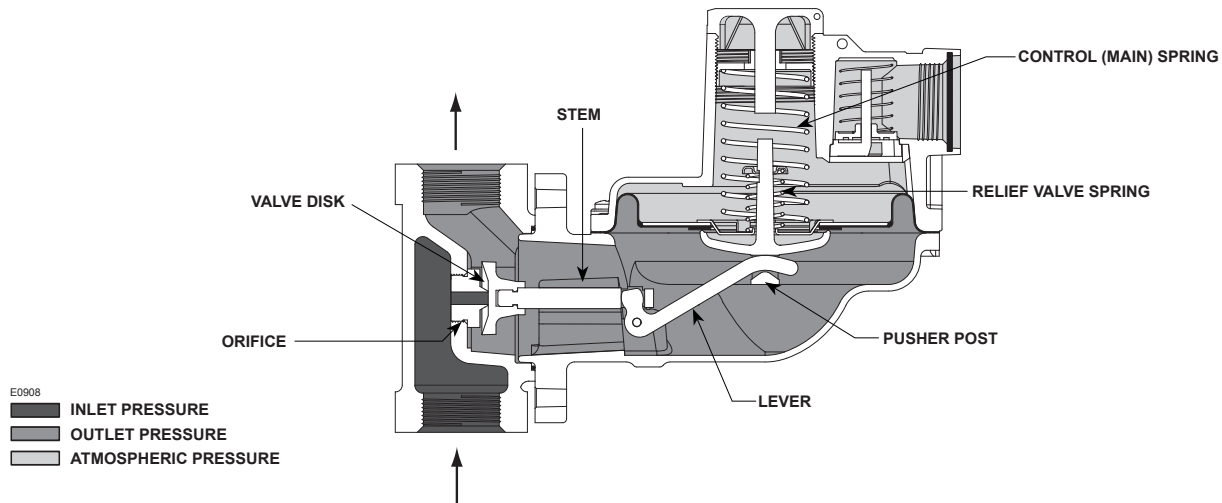

Figure 2. Type HSR Pressure Regulator Operational Schematic

Table 1. Maximum Operating Inlet Pressure

ORIFICE SIZE		WIDE-OPEN C_g FOR RELIEF SIZING	MAXIMUM OPERATING INLET PRESSURE TO OBTAIN GOOD REGULATING PERFORMANCE	
Inch	mm		psig	bar
1/8	3.2	12.5	125	8.6
3/16	4.8	28.2	100	6.9
1/4	6.4	50.0	60	4.1
3/8	9.5	105	30	2.1
1/2	13	185	20	1.2

Table 2. Outlet Pressure Ranges

OUTLET PRESSURE RANGE		SPRING PART NUMBER	SPRING COLOR	STANDARD CLOSING CAP COLOR	SPRING WIRE DIAMETER		SPRING FREE LENGTH	
Inches w.c.	mbar				Inch	mm	Inch	mm
4 to 6	10 to 15	T14398T0012	Orange	Black	0.062	1.57	3.40	86.4
6 to 8	15 to 20	T14399T0012	Yellow	Black	0.067	1.70	3.61	91.4
8 to 10	20 to 25	T14405T0012	Black	Black	0.067	1.70	3.71	94.0
10 to 12.5	25 to 31	T14400T0012	Silver	Black	0.072	1.83	4.10	104
12.5 to 20	31 to 50	T14401T0012	Gray	Black	0.080	2.03	3.60	91.4
20 to 35	50 to 87	T14402T0012	Pink	Black	0.093	2.36	3.52	88.9
1.25 to 2.2 psig	0.09 to 0.15 bar	T14403T0012	Light Blue	Red	0.105	2.67	3.66	94.0

Table 3. Standard Outlet Pressures and Set Flows

OUTLET PRESSURE RANGE		STANDARD OUTLET SET PRESSURE		STANDARD SET GAS FLOW, SCFH / Nm ³ /h
Inches w.c.	mbar	Inches w.c.	mbar	
4 to 6	10 to 15	5	12	50 / 1.3
6 to 8	15 to 20	7	17	
8 to 10	20 to 25	9	22	
10 to 12.5	25 to 31	11	27	
12.5 to 20	31 to 50	14	35	
20 to 35	50 to 87	1 psi	0.07 bar	
1.25 to 2.2 psig	0.09 to 0.15 bar	2 psi	0.14 bar	

Table 4. Flow and Sizing Coefficients

ORIFICE SIZE		WIDE-OPEN RESIZING RELIEF SIZING		C_1	IEC SIZING COEFFICIENTS		
Inch	mm	C_g	C_v		X_T	F_D	F_L
1/8	3.2	12.5	0.36	35	0.78	0.82	0.89
3/16	4.8	28.2	0.81			0.82	
1/4	6.4	50	1.43			0.82	
3/8	9.5	105	3.00			0.79	
1/2	13	185	5.29			0.79	

Bulletin 71.1:HSR

Table 5. Standard Inlet Pressures for Set Flows

ORIFICE SIZE		INLET PRESSURE FOR SET FLOWS	
Inches	mm	psi	bar
1/8	3.2	60	4.1
3/16	4.8	50	3.5
1/4	6.4	30	2.1
3/8	9.5	15	1.0
1/2	13	10	0.69

For each orifice size, the outlet pressure setting is made with the same inlet pressure regardless of outlet pressure. Example: 3/16-inch / 4.8 mm orifice uses 50 psi / 3.5 bar inlet for 5-inches w.c. through 2 psi / 12 mbar through 0.14 bar outlet settings.

Principle of Operation

Refer to Figure 2. When downstream demand decreases, the pressure under the diaphragm increases. This pressure overcomes the regulator setting (which is set by a spring). Through the action of the pusher post assembly, lever, and stem the valve disk moves closer to the orifice and reduces gas flow. If demand downstream increases, pressure under the diaphragm decreases. Spring force pushes the pusher post assembly downward and the valve disk moves away from the orifice. Type HSR regulators include an internal relief valve for overpressure protection. If the downstream pressure exceeds the regulator setting by 7-inches w.c. to 1.25 psig / 17 mbar to 0.09 bar, depending on the main spring used, the relief valve opens and excess gas escapes through the vent in the upper spring case.

Installation

The HSR Series regulators may be installed in any position. However, the spring case vent should be pointed downward. If gas escaping through the Type HSR internal relief valve could constitute a hazard, the spring case vent must be piped to a location where escaping gas will not be hazardous. If the vented gas will be piped to another location, obstruction-free tubing or piping at least equal to the vent, and the end of the vent pipe must be protected from anything that might clog it. Dimensions are shown in Figure 6.

Type HSR Flow Capacity for Pressure Factor Measurement

Tables 6 and 7 contain the flow capacities for the Type HSR at accuracies of +/- 1% of absolute pressure. This data can be used in applying the regulator in Pressure Factor Measurement (also called Fixed Factor Measurement) or other applications requiring better accuracy. Normally pilot operated regulators with high accuracy are required for these applications. However, as shown in the table, by flow testing and by limiting the droop on flow capacity, +/- 1% of absolute pressure is obtained.

Overpressure Protection

The wide-open C_g for relief sizing (see Table 1) along with the capacity information should be used in choosing appropriate overpressure protection devices to ensure that none of the limits in the Specifications section are exceeded.

Overpressuring any portion of a regulator or associated equipment may cause leakage, parts damage, or personal injury due to bursting of pressure-containing parts or explosion of accumulated gas. Regulator operation within ratings does not prevent the possibility of damage from external sources or from debris in the pipeline. A regulator should be inspected for damage after any overpressure condition.

Capacity Information

The high efficiency flow-through design provides maximum capacity for a given orifice size. Tables 8 through 1 give the HSR Series flow capacities at selected inlet pressures and outlet pressure settings. Flows are in SCFH (at 60°F and 14.7 psia) and Nm³/h (at 0°C and 1.01325 bar) of 0.6 specific gravity natural gas. To determine equivalent capacities for air, propane, butane, or nitrogen, multiply the listed SCFH capacity by the following appropriate conversion factor: air—0.775 for air, propane—0.628, butane—0.548, nitrogen—0.789. For gases of other specific gravities, multiply the given SCFH capacity by 0.775 and divide by the square root of the appropriate specific gravity. If capacity is desired in Nm³/h, multiply SCFH by 0.0268.

For Critical Pressure Drops

Use this equation for critical pressure drops (absolute outlet pressure equal to one-half or less than one-half the absolute inlet pressure).

$$Q = P_{1(ABS)} C_g (1.29)$$

where,

- Q = gas flow rate, SCFH
- C_g = gas sizing coefficient
- P_1 = absolute inlet pressure, psia

For Non-Critical Pressure Drops

For pressure drops lower than critical (absolute outlet pressure greater than one-half of absolute inlet pressure), use the following formula:

$$Q = \sqrt{\frac{520}{GT}} C_g P_1 \text{SIN} \left(\frac{3417}{C_1} \sqrt{\frac{\Delta P}{P_1}} \right) \text{DEG}$$

where,

- Q = gas flow rate, SCFH
- G = specific gravity of the gas
- T = absolute temperature of gas at inlet, °Rankine
- C_g = gas sizing coefficient
- P_1 = absolute inlet pressure, psia
- C_1 = flow coefficient
- ΔP = pressure drop across the regulator, psi

Then, if capacity is desired in normal cubic meters per hour at 0°C and 1.01325 bar, multiply SCFH by 0.0268.

Ordering Information

Carefully review each specification and complete the Ordering Guide on page 20. Send the Ordering Guide to your local Sales Office.

Table 6. Typical HSR Regulating Capacities for a 3/4 NPT Outlet Body Size with 1% Pressure Factor Accuracy

OUTLET PRESSURE SETTING SPRING RANGE DROOP/BOOST	INLET PRESSURE		CAPACITIES IN SCFH / Nm ³ /h OF 0.6 SPECIFIC GRAVITY GAS				
	psig	bar	Orifice Size, Inches / mm				
			1/8 / 3.2 ⁽¹⁾	3/16 / 4.8 ⁽¹⁾	1/4 / 6.4 ⁽¹⁾	3/8 / 9.5 ⁽²⁾	1/2 / 13 ⁽²⁾
1 psig / 0.07 bar Spring T14402T0012 Color: Pink +/- 1% ABS	2	0.14			220 / 5.9	390 / 10.5	570 / 15.3
	3	0.21		220 / 5.9	350 / 9.4	570 / 15.3	770 / 20.6
	5	0.34	200 / 5.4	380 / 10.2	520 / 13.9	830 / 22.2	1040 / 27.9
	10	0.69	330 / 8.8	600 / 16.1	890 / 23.9	1400 / 37.5	1710 / 45.8
	15	1.0	410 / 11.0	810 / 21.7	1250 / 33.5	1750 / 46.9	2150 / 57.6
	20	1.4	510 / 13.7	1050 / 28.1	1520 / 40.7	2050 / 54.9	2380 / 63.8
	30	2.1	660 / 17.7	1500 / 40.2	2020 / 54.1	2400 / 64.3	
	40	2.8	830 / 22.2	1850 / 49.6	2320 / 62.2		
	50	3.5	970 / 26.0	2120 / 56.8	2580 / 69.1		
	60	4.1	1130 / 30.3	2400 / 64.3	2850 / 76.4		
	80	5.5	1440 / 38.6	2600 / 69.7			
	100	6.9	1760 / 47.2	2700 / 72.4			
	125	8.6	2150 / 57.6				
	2 psig / 0.14 bar Spring T14403T0012 Color: Light Blue +/- 1% ABS	3	0.21			200 / 5.4	300 / 8.0
5		0.34		250 / 6.7	350 / 9.4	510 / 13.7	750 / 20.1
10		0.69	250 / 6.7	450 / 12.1	650 / 17.4	1020 / 27.3	1340 / 35.9
15		1.0	380 / 10.2	620 / 16.6	950 / 25.5	1350 / 36.2	1820 / 48.8
20		1.4	480 / 12.9	780 / 20.9	1210 / 32.4	1680 / 45.0	2120 / 56.8
30		2.1	650 / 17.4	1150 / 30.8	1680 / 45.0	2220 / 59.5	
40		2.8	800 / 21.4	1500 / 40.2	1950 / 52.3		
50		3.5	920 / 24.7	2020 / 54.1	2300 / 61.6		
60		4.1	1100 / 29.5	2250 / 60.3	2550 / 68.3		
80		5.5	1450 / 39.5	2500 / 67.0			
100		6.9	1750 / 46.9	2750 / 73.7			
125		8.6	2000 / 53.6				

1. Setpoint was established with an inlet of 10 psig / 0.69 bar. The regulators were not reset as inlet pressure was increased or decreased.
 2. Setpoint was established with an inlet of 5 psig / 0.34 bar. The regulators were not reset as inlet pressure was increased or decreased.
 Gray areas show where indicated droop/boost would be exceeded regardless of capacity.
 Blank areas indicate where maximum operating inlet pressure is exceeded for a given orifice.

Table 7. Typical HSR Regulating Capacities for a 1 NPT Outlet Body Size with 1% Pressure Factor Accuracy

OUTLET PRESSURE SETTING SPRING RANGE DROOP/BOOST	INLET PRESSURE		CAPACITIES IN SCFH / Nm ³ /h OF 0.6 SPECIFIC GRAVITY GAS				
	psig	bar	Orifice Size, Inches / mm				
			1/8 / 3.2 ⁽¹⁾	3/16 / 4.8 ⁽¹⁾	1/4 / 6.4 ⁽¹⁾	3/8 / 9.5 ⁽²⁾	1/2 / 13 ⁽²⁾
1 psig / 0.07 bar Spring T14402T0012 Color: Pink +/- 1% ABS	2	0.14			220 / 5.9	390 / 10.5	570 / 15.3
	3	0.21		220 / 5.9	350 / 9.4	570 / 15.3	770 / 20.6
	5	0.34	200 / 5.4	380 / 10.2	520 / 13.9	830 / 22.2	1150 / 30.8
	10	0.69	330 / 8.8	600 / 16.1	890 / 23.9	1400 / 37.5	1980 / 53.1
	15	1.0	410 / 11.0	810 / 21.7	1250 / 33.5	2050 / 54.9	2550 / 68.3
	20	1.4	510 / 13.7	1050 / 28.1	1520 / 40.7	2600 / 69.7	3000 / 80.4
	30	2.1	660 / 17.7	1500 / 40.2	2020 / 54.1	3450 / 92.5	
	40	2.8	830 / 22.2	1850 / 49.6	2500 / 67.0		
	50	3.5	970 / 26.0	2120 / 56.8	2900 / 77.7		
	60	4.1	1130 / 30.3	2500 / 67.0	3400 / 91.1		
	80	5.5	1440 / 38.6	3250 / 87.1			
	100	6.9	1760 / 47.2	3950 / 106			
	125	8.6	2150 / 57.6				
	2 psig / 0.14 bar Spring T14403T0012 Color: Light Blue +/- 1% ABS	3	0.21			200 / 5.4	300 / 8.0
5		0.34		250 / 6.7	350 / 9.4	510 / 13.7	750 / 20.1
10		0.69	250 / 6.7	450 / 12.1	650 / 17.4	1020 / 27.3	1450 / 38.9
15		1.0	380 / 10.2	620 / 16.6	950 / 25.5	1510 / 40.5	198 / 53.1
20		1.4	480 / 12.9	780 / 20.9	1210 / 32.4	1900 / 50.9	2350 / 63.0
30		2.1	650 / 17.4	1150 / 30.8	1780 / 47.7	2800 / 75.0	
40		2.8	800 / 21.4	1500 / 40.2	2080 / 55.7		
50		3.5	920 / 24.7	2020 / 54.1	2550 / 68.3		
60		4.1	1100 / 29.5	2250 / 60.3	3000 / 80.4		
80		5.5	1450 / 38.9	2800 / 75.0			
100		6.9	1750 / 46.9	3500 / 93.8			
125		8.6	2000 / 53.6				

1. Setpoint was established with an inlet of 10 psig / 0.69 bar. The regulators were not reset as inlet pressure was increased or decreased.
 2. Setpoint was established with an inlet of 5 psig / 0.34 bar. The regulators were not reset as inlet pressure was increased or decreased.
 Gray areas show where indicated droop/boost would be exceeded regardless of capacity.
 Blank areas indicate where maximum operating inlet pressure is exceeded for a given orifice.

Bulletin 71.1:HSR

Table 8. 3/4 NPT Globe Body Capacities

OUTLET PRESSURE SETTING, SPRING RANGE, DROOP, AND BOOST	INLET PRESSURE		CAPACITIES IN SCFH / Nm ³ /h OF 0.6 SPECIFIC GRAVITY NATURAL GAS				
			Orifice Size, Inches / mm				
	psig	bar	1/8 / 3.2	3/16 / 4.8	1/4 / 6.4	3/8 / 9.5	1/2 / 13
5-inches w.c. / 12 mbar 4 to 6-inches w.c. / 10 to 15 mbar 1-inch w.c. droop 2-inches w.c. boost	0.5	0.03	----	----	190 / 5.1	240 / 6.4	285 / 7.6
	1	0.07	95 / 92.5	220 / 5.9	250 / 6.7	330 / 8.8	400 / 10.7
	2	0.14	150 / 4.0	250 / 6.7	335 / 9.0	490 / 13.1	650 / 17.4
	3	0.21	185 / 5.0	290 / 7.8	430 / 11.5	600 / 16.1	750 / 20.1
	5	0.34	235 / 6.3	400 / 10.7	580 / 15.5	900 / 24.1	1100 / 29.5
	10	0.69	325 / 8.7	775 / 20.8	1050 / 28.1	1200 / 32.2	
	15	1.0	420 / 11.3	980 / 26.3	1295 / 34.7		
	20	1.4	500 / 13.4	1120 / 30.0	1380 / 37.0		
	30	2.1	655 / 17.6	1475 / 39.5			
	40	2.8	820 / 22.0	1785 / 47.8			
	50	3.5	945 / 25.3	2150 / 57.6			
	60	4.1	1100 / 29.5				
	80	5.5	1400 / 37.5				
100	6.9	1700 / 45.6					
7-inches w.c. / 17 mbar 6 to 8-inches w.c. / 15 to 20 mbar 1-inch w.c. droop 2-inches w.c. boost	0.5	0.03	70 / 1.9	120 / 3.2	170 / 4.6	240 / 6.4	300 / 8.0
	1	0.07	100 / 2.7	180 / 4.8	240 / 6.4	340 / 9.1	430 / 11.5
	2	0.14	130 / 3.5	250 / 6.7	330 / 8.8	510 / 13.7	630 / 16.9
	3	0.21	170 / 4.6	340 / 9.1	420 / 11.3	680 / 18.2	770 / 20.6
	5	0.34	220 / 5.9	420 / 11.3	650 / 17.4	900 / 24.1	960 / 25.7
	10	0.69	330 / 8.8	730 / 19.6	1100 / 29.5	1310 / 35.1	1310 / 35.1
	15	1.0	430 / 11.5	1000 / 26.8	1380 / 37.0	1520 / 40.7	1520 / 40.7
	20	1.4	530 / 14.2	1200 / 32.2	1560 / 41.8	1620 / 43.4	1620 / 43.4
	30	2.1	680 / 18.2	1550 / 41.5	1840 / 49.3	1750 / 46.9	
	40	2.8	850 / 22.8	1900 / 50.9	1950 / 52.3		
	50	3.5	970 / 26.0	2200 / 59.0	2000 / 53.6		
	60	4.1	1150 / 30.8	2280 / 61.1	2100 / 56.3		
	80	5.5	1450 / 38.9	2350 / 63.0			
100	6.9	1750 / 46.9	1900 / 50.9				
125	8.6	2100 / 56.3					
9-inches w.c. / 22 mbar 8 to 10-inches w.c. / 20 to 25 mbar 1-inch w.c. droop 2-inches w.c. boost	1	0.07	----	140 / 3.7	170 / 4.6	240 / 6.4	325 / 8.7
	2	0.14	125 / 3.4	190 / 5.1	225 / 6.0	345 / 9.3	475 / 12.7
	3	0.21	190 / 5.1	220 / 5.9	270 / 7.2	475 / 12.7	660 / 17.7
	5	0.34	210 / 5.6	275 / 7.4	400 / 10.7	685 / 18.4	880 / 23.6
	10	0.69	280 / 7.5	440 / 11.8	710 / 19.0	1235 / 33.1	1215 / 32.6
	15	1.0	370 / 9.9	685 / 18.4	1235 / 33.1	1400 / 37.5	1400 / 37.5
	20	1.4	485 / 13.0	945 / 25.3	1475 / 39.5	1540 / 41.3	1500 / 40.2
	30	2.1	680 / 18.2	1475 / 39.5	1800 / 48.2	1690 / 45.3	
	40	2.8	835 / 22.4	1770 / 47.4	1925 / 51.6		
	50	3.5	990 / 26.5	2000 / 53.6	1960 / 52.5		
	60	4.1	1135 / 30.4	2155 / 57.7	2050 / 54.9		
	80	5.5	1440 / 38.6	2265 / 60.7			
	100	6.9	1750 / 46.9	2100 / 56.3			
125	8.6	2120 / 56.8					

Gray areas indicate capacities limited by either droop or boost.
Blank areas indicate where maximum operating inlet pressure is exceeded for a given orifice.

- continued -

Table 8. 3/4 NPT Globe Body Capacities (continued)

OUTLET PRESSURE SETTING, SPRING RANGE, DROOP, AND BOOST	INLET PRESSURE		CAPACITIES IN SCFH / Nm ³ /h OF 0.6 SPECIFIC GRAVITY NATURAL GAS				
			Orifice Size, Inches / mm				
	psig	bar	1/8 / 3.2	3/16 / 4.8	1/4 / 6.4	3/8 / 9.5	1/2 / 13
11-inches w.c. / 27 mbar 10 to 12.5-inches w.c. / 25 to 31 mbar 1-inch w.c. droop 2-inches w.c. boost	1	0.07	80 / 2.1	150 / 4.0	200 / 5.4	240 / 6.4	330 / 8.8
	2	0.14	120 / 3.2	200 / 5.4	270 / 7.2	420 / 11.3	530 / 14.2
	3	0.21	150 / 4.0	250 / 6.7	350 / 9.4	530 / 14.2	680 / 18.2
	5	0.34	190 / 5.1	340 / 9.1	480 / 12.9	770 / 20.6	860 / 23.1
	10	0.69	290 / 7.8	550 / 14.7	910 / 24.4	1210 / 32.4	1210 / 32.4
	15	1.0	400 / 10.7	840 / 22.5	1210 / 32.4	1380 / 37.0	1380 / 37.0
	20	1.4	480 / 12.9	1140 / 30.6	1550 / 41.5	1590 / 42.6	1590 / 42.6
	30	2.1	670 / 18.0	1530 / 41.0	1830 / 49.0	1810 / 48.5	
	40	2.8	820 / 22.0	1970 / 52.8	1950 / 52.3		
	50	3.5	970 / 26.0	2150 / 57.6	1990 / 53.3		
	60	4.1	1120 / 30.0	2260 / 60.6	2050 / 54.9		
	80	5.5	1420 / 38.0	2390 / 64.1			
	100	6.9	1730 / 46.4	1950 / 52.3			
125	8.6	2110 / 56.6					
14-inches w.c. / 35 mbar 12.5 to 20-inches w.c. / 31 to 50 mbar 2-inches w.c. droop 2-inches w.c. boost	1	0.07	80 / 2.1	140 / 3.8	190 / 5.1	290 / 7.8	330 / 8.8
	2	0.14	120 / 3.2	230 / 6.2	300 / 8.0	430 / 11.5	570 / 15.3
	3	0.21	160 / 4.3	290 / 7.8	360 / 9.6	580 / 15.5	730 / 19.6
	5	0.34	210 / 5.6	360 / 9.6	500 / 13.4	760 / 20.4	970 / 26.0
	10	0.69	320 / 8.6	570 / 15.3	890 / 23.9	1190 / 31.9	1290 / 34.6
	15	1.0	410 / 11.0	820 / 22.0	1210 / 32.4	1460 / 39.1	1560 / 41.8
	20	1.4	500 / 13.4	1050 / 28.1	1440 / 38.6	1660 / 44.5	1700 / 45.6
	30	2.1	670 / 18.0	1500 / 40.2	1790 / 48.0	1850 / 49.6	
	40	2.8	830 / 22.2	1830 / 49.0	2020 / 54.1		
	50	3.5	970 / 26.0	2100 / 56.3	2100 / 56.3		
	60	4.1	1140 / 30.6	2120 / 56.8	2180 / 58.4		
	80	5.5	1440 / 38.6	2220 / 59.5			
	100	6.9	1770 / 47.4	2250 / 60.3			
125	8.6	2140 / 57.4					
28-inches w.c. / 70 mbar 20 to 35-inches w.c. / 50 to 87 mbar ± 1% ABS	2	0.14	120 / 3.2	250 / 6.7	310 / 8.3	420 / 11.3	570 / 15.3
	3	0.21	150 / 4.0	280 / 7.5	380 / 10.2	570 / 15.3	770 / 20.6
	5	0.34	220 / 5.9	380 / 10.2	550 / 14.7	830 / 22.2	1040 / 27.9
	10	0.69	330 / 8.8	600 / 16.1	890 / 23.9	1310 / 35.1	1570 / 42.1
	15	1.0	410 / 11.0	810 / 21.7	1220 / 32.7	1600 / 42.9	1860 / 49.9
	20	1.4	510 / 13.7	1020 / 27.3	1490 / 39.9	1790 / 48.0	2020 / 54.1
	30	2.1	660 / 17.7	1440 / 38.6	1820 / 48.8	2100 / 56.3	
	40	2.8	830 / 22.2	1800 / 48.2	2080 / 55.7		
	50	3.5	970 / 26.0	1980 / 53.1	2280 / 61.1		
	60	4.1	1130 / 30.3	2320 / 62.2	2380 / 63.8		
	80	5.5	1440 / 38.6	2400 / 64.3			
	100	6.9	1760 / 47.2	2500 / 67.0			
	125	8.6	2150 / 57.6				

Gray areas indicate capacities limited by either droop or boost.
Blank areas indicate where maximum operating inlet pressure is exceeded for a given orifice.

- continued -

Bulletin 71.1:HSR

Table 8. 3/4 NPT Globe Body Capacities (continued)

OUTLET PRESSURE SETTING, SPRING RANGE, DROOP, AND BOOST	INLET PRESSURE		CAPACITIES IN SCFH / Nm ³ /h OF 0.6 SPECIFIC GRAVITY NATURAL GAS				
			Orifice Size, Inches / mm				
	psig	bar	1/8 / 3.2	3/16 / 4.8	1/4 / 6.4	3/8 / 9.5	1/2 / 13
28-inches w.c. / 70 mbar 20 to 35-inches w.c. / 50 to 87 mbar ± 2% ABS	2	0.14	150 / 4.0	310 / 8.3	470 / 12.6	710 / 19.0	930 / 24.9
	3	0.21	180 / 4.8	390 / 10.5	590 / 15.8	940 / 25.2	1230 / 33.0
	5	0.34	250 / 6.7	530 / 14.2	840 / 22.5	1290 / 34.6	1600 / 42.9
	10	0.69	360 / 9.6	810 / 21.7	1320 / 35.4	1890 / 50.7	2200 / 59.0
	15	1.0	430 / 11.5	1010 / 27.1	1650 / 44.2	2290 / 61.4	2530 / 67.8
	20	1.4	530 / 14.2	1200 / 32.2	1940 / 52.0	2490 / 66.7	2750 / 73.7
	30	2.1	670 / 18.0	1570 / 42.1	2430 / 65.1	2900 / 77.7	
	40	2.8	830 / 22.2	1920 / 51.5	2720 / 72.9		
	50	3.5	970 / 26.0	2280 / 61.1	2830 / 75.8		
	60	4.1	1130 / 30.3	2630 / 70.5	3050 / 81.7		
	80	5.5	1440 / 38.6	3050 / 81.7			
	100	6.9	1760 / 47.2	3150 / 84.4			
125	8.6	2150 / 57.6					
2 psig / 0.14 bar 1.25 to 2.2 psig / 0.09 to 0.15 bar ± 1% ABS	3	0.21	120 / 3.2	190 / 5.1	250 / 6.7	330 / 8.8	450 / 12.1
	5	0.34	150 / 4.0	270 / 7.2	360 / 9.6	560 / 15.0	750 / 20.1
	10	0.69	250 / 6.7	430 / 11.5	620 / 16.6	1020 / 27.3	1340 / 35.9
	15	1.0	330 / 8.8	600 / 16.1	800 / 21.4	1350 / 36.2	1480 / 39.7
	20	1.4	410 / 11.0	740 / 19.8	1040 / 27.9	1540 / 41.3	1800 / 48.2
	30	2.1	560 / 15.0	1050 / 28.1	1450 / 38.9	1850 / 49.6	
	40	2.8	730 / 19.6	1320 / 35.4	1640 / 44.0		
	50	3.5	870 / 23.3	1620 / 43.4	1900 / 50.9		
	60	4.1	1030 / 27.6	1910 / 51.2	2140 / 57.4		
	80	5.5	1350 / 36.2	2090 / 56.0			
	100	6.9	1650 / 44.2	2180 / 58.4			
	125	8.6	2000 / 53.6				
2 psig / 0.14 bar 1.25 to 2.2 psig / 0.09 to 0.15 bar ± 2% ABS	3	0.21	150 / 4.0	270 / 7.2	420 / 11.3	600 / 16.1	790 / 21.2
	5	0.34	210 / 5.6	420 / 11.3	620 / 16.6	960 / 25.7	1230 / 33.0
	10	0.69	340 / 9.1	700 / 18.8	1050 / 28.1	1430 / 38.3	1880 / 50.4
	15	1.0	440 / 11.8	940 / 25.2	1350 / 36.2	1880 / 50.4	2230 / 59.8
	20	1.4	520 / 13.9	1150 / 30.8	1620 / 43.4	2260 / 60.6	2540 / 68.1
	30	2.1	670 / 18.0	1540 / 41.3	2110 / 56.6	2520 / 67.5	
	40	2.8	830 / 22.2	1880 / 50.4	2430 / 65.1		
	50	3.5	970 / 26.0	2170 / 58.2	2640 / 70.8		
	60	4.1	1130 / 30.3	2460 / 65.9	2850 / 76.4		
	80	5.5	1450 / 38.9	2850 / 76.4			
	100	6.9	1750 / 46.9	3000 / 80.4			
	125	8.6	2100 / 56.3				

Blank areas indicate where maximum operating inlet pressure is exceeded for a given orifice.

Table 9. 3/4 x 1 NPT Globe Body Capacities

OUTLET PRESSURE SETTING, SPRING RANGE, DROOP, AND BOOST	INLET PRESSURE		CAPACITIES IN SCFH / Nm ³ /h OF 0.6 SPECIFIC GRAVITY NATURAL GAS				
			Orifice Size, Inches / mm				
	psig	bar	1/8 / 3.2	3/16 / 4.8	1/4 / 6.4	3/8 / 9.5	1/2 / 13
5-inches w.c. / 12 mbar 4 to 6-inches w.c. / 10 to 15 mbar 1-inch w.c. droop 2-inches w.c. boost	0.5	0.03	----	----	190 / 5.1	240 / 6.4	285 / 7.6
	1	0.07	110 / 3.0	220 / 5.9	250 / 6.7	355 / 9.5	450 / 12.1
	2	0.14	170 / 4.6	250 / 6.7	340 / 9.1	490 / 13.1	770 / 20.6
	3	0.21	210 / 5.6	340 / 9.1	500 / 13.4	750 / 20.1	1000 / 26.8
	5	0.34	245 / 6.6	400 / 10.7	750 / 20.1	1190 / 31.9	1330 / 35.6
	10	0.69	375 / 10.1	785 / 21.0	1290 / 34.6	1585 / 42.5	
	15	1.0	475 / 12.7	995 / 26.7	1590 / 42.6		
	20	1.4	565 / 15.1	1160 / 31.1	1850 / 49.6		
	30	2.1	740 / 19.8	1475 / 39.5			
	40	2.8	900 / 24.1	1840 / 49.3			
	50	3.5	1050 / 28.1	2180 / 58.4			
	60	4.1	1215 / 32.6				
	80	5.5	1555 / 41.7				
100	6.9	1880 / 50.4					
9-inches w.c. / 22 mbar 8 to 10-inches w.c. / 20 to 25 mbar 1-inch w.c. droop 2-inches w.c. boost	1	0.07	----	150 / 4.0	170 / 4.6	240 / 6.4	325 / 8.7
	2	0.14	125 / 3.4	190 / 5.1	225 / 6.0	345 / 9.3	475 / 12.7
	3	0.21	195 / 5.2	220 / 5.9	270 / 7.2	475 / 12.7	660 / 17.7
	5	0.34	210 / 5.6	275 / 7.4	400 / 10.7	685 / 18.4	880 / 23.6
	10	0.69	280 / 7.5	440 / 11.8	710 / 19.0	1235 / 33.1	1250 / 33.5
	15	1.0	370 / 9.9	685 / 18.4	1360 / 36.4	1585 / 42.5	1400 / 37.5
	20	1.4	485 / 13.0	945 / 25.3	1610 / 43.1	1820 / 48.8	1540 / 41.3
	30	2.1	680 / 18.2	1485 / 39.8	2080 / 55.7	2110 / 56.6	
	40	2.8	885 / 23.7	1840 / 49.3	2300 / 61.6		
	50	3.5	1050 / 28.1	2150 / 57.6	2760 / 74.0		
	60	4.1	1215 / 32.6	2475 / 66.3	3115 / 83.5		
	80	5.5	1530 / 41.0	3150 / 84.4			
	100	6.9	1855 / 49.7	2900 / 77.7			
125	8.6	2300 / 61.6					

Gray areas indicate capacities limited by either droop or boost.
 Blank areas indicate where maximum operating inlet pressure is exceeded for a given orifice.

Bulletin 71.1:HSR

Table 10. 1 NPT Globe Body Capacities

OUTLET PRESSURE SETTING, SPRING RANGE, DROOP, AND BOOST	INLET PRESSURE		CAPACITIES IN SCFH / Nm ³ /h OF 0.6 SPECIFIC GRAVITY NATURAL GAS				
			Orifice Size, Inches / mm				
	psig	bar	1/8 / 3.2	3/16 / 4.8	1/4 / 6.4	3/8 / 9.5	1/2 / 13
7-inches w.c. / 17 mbar 6 to 8-inches w.c. / 15 to 20 mbar 1-inch w.c. droop 2-inches w.c. boost	0.5	0.03	70 / 1.9	120 / 3.2	170 / 4.7	240 / 6.5	300 / 8.0
	1	0.07	100 / 2.7	180 / 4.8	240 / 6.4	340 / 9.1	430 / 11.5
	2	0.14	130 / 3.5	250 / 6.7	330 / 8.8	510 / 13.7	630 / 16.9
	3	0.21	170 / 4.7	340 / 9.1	420 / 11.3	680 / 18.2	770 / 20.6
	5	0.34	220 / 5.9	420 / 11.3	650 / 17.4	960 / 25.7	1080 / 28.9
	10	0.69	330 / 8.8	730 / 19.6	1100 / 29.5	1310 / 35.1	1600 / 42.9
	15	1.0	430 / 11.5	1000 / 26.8	1440 / 38.6	1770 / 47.4	1800 / 48.2
	20	1.4	530 / 14.2	1200 / 32.2	1810 / 48.5	2100 / 56.3	1960 / 52.5
	30	2.1	680 / 18.2	1550 / 41.5	2100 / 56.3	2450 / 65.7	
	40	2.8	850 / 22.8	1900 / 50.9	2150 / 57.6		
	50	3.5	970 / 26.0	2200 / 59.0	2690 / 72.1		
	60	4.1	1150 / 30.8	2280 / 61.1	3010 / 80.7		
	80	5.5	1450 / 38.9	2350 / 63.0			
100	6.9	1750 / 46.9	1900 / 50.9				
125	8.6	2100 / 56.3					
11-inches w.c. / 27 mbar 10 to 12.5-inches w.c. / 25 to 31 mbar 1-inch w.c. droop 2-inches w.c. boost	1	0.07	80 / 2.1	150 / 4.0	200 / 5.4	240 / 6.4	330 / 8.8
	2	0.14	120 / 3.2	200 / 5.4	270 / 7.2	420 / 11.3	530 / 14.2
	3	0.21	150 / 4.0	250 / 6.7	350 / 9.4	530 / 14.2	680 / 18.2
	5	0.34	190 / 5.1	340 / 9.1	480 / 12.9	770 / 20.6	870 / 23.3
	10	0.69	290 / 7.8	550 / 14.7	910 / 24.4	1230 / 33.0	1350 / 36.2
	15	1.0	400 / 10.7	840 / 22.5	1290 / 34.6	1450 / 38.9	1630 / 43.7
	20	1.4	480 / 12.9	1140 / 30.6	1420 / 38.1	1650 / 44.2	1870 / 50.1
	30	2.1	670 / 18.0	1530 / 41.0	1680 / 45.0	2100 / 56.3	
	40	2.8	820 / 22.0	1970 / 52.8	1750 / 46.9		
	50	3.5	970 / 26.0	2150 / 57.6	1840 / 49.3		
	60	4.1	1120 / 30.0	2260 / 60.6	2130 / 57.1		
	80	5.5	1420 / 38.1	2390 / 64.1			
	100	6.9	1730 / 46.4	1950 / 52.3			
125	8.6	2110 / 56.6					
14-inches w.c. / 35 mbar 12.5 to 20-inches w.c. / 31 to 50 mbar 2-inches w.c. droop 2-inches w.c. boost	1	0.07	80 / 2.1	140 / 3.7	190 / 5.1	290 / 7.8	330 / 8.8
	2	0.14	120 / 3.2	230 / 6.2	300 / 8.0	430 / 11.5	570 / 15.3
	3	0.21	160 / 4.3	290 / 7.8	360 / 9.7	580 / 15.5	730 / 19.6
	5	0.34	210 / 5.6	360 / 9.7	500 / 13.4	760 / 20.8	970 / 26.0
	10	0.69	320 / 8.6	570 / 15.3	890 / 23.9	1190 / 31.9	1530 / 41.0
	15	1.0	410 / 11.0	820 / 22.0	1210 / 32.4	1460 / 39.1	1780 / 47.7
	20	1.4	500 / 13.4	1050 / 28.1	1440 / 38.6	1660 / 44.5	1950 / 52.3
	30	2.1	670 / 18.0	1500 / 40.2	1790 / 48.0	2200 / 59.0	
	40	2.8	830 / 22.2	1830 / 49.0	2020 / 54.1		
	50	3.5	970 / 26.0	2100 / 56.3	2100 / 56.3		
	60	4.1	1140 / 30.6	2350 / 63.0	2180 / 58.4		
	80	5.5	1440 / 38.6	3000 / 80.4			
	100	6.9	1770 / 47.4	2550 / 68.3			
125	8.6	2140 / 57.4					

Gray areas indicate capacities limited by either droop or boost.
Blank areas indicate where maximum operating inlet pressure is exceeded for a given orifice.

- continued -

Table 10. 1 NPT Globe Body Capacities (continued)

OUTLET PRESSURE SETTING, SPRING RANGE, DROOP, AND BOOST	INLET PRESSURE		CAPACITIES IN SCFH / Nm ³ /h OF 0.6 SPECIFIC GRAVITY NATURAL GAS				
			Orifice Size, Inches / mm				
	psig	bar	1/8 / 3.2	3/16 / 4.8	1/4 / 6.4	3/8 / 9.5	1/2 / 13
28-inches w.c. / 70 mbar 20 to 35-inches w.c. / 50 to 87 mbar ± 1% ABS	2	0.14	120 / 3.2	250 / 6.7	310 / 8.3	420 / 11.3	570 / 15.3
	3	0.21	150 / 4.0	280 / 7.5	380 / 10.2	570 / 15.3	770 / 20.6
	5	0.34	220 / 5.9	380 / 10.2	550 / 14.7	830 / 22.2	1040 / 27.9
	10	0.69	330 / 8.8	600 / 16.1	890 / 23.9	1310 / 35.1	1570 / 42.1
	15	1.0	410 / 11.0	810 / 21.7	1220 / 32.7	1600 / 42.9	2000 / 53.6
	20	1.4	510 / 13.7	1020 / 27.3	1490 / 39.9	2000 / 53.6	2300 / 61.6
	30	2.1	660 / 17.7	1440 / 38.6	1820 / 48.8	2450 / 65.7	
	40	2.8	830 / 22.2	1800 / 48.2	2080 / 55.7		
	50	3.5	970 / 26.0	2120 / 56.8	2430 / 65.1		
	60	4.1	1130 / 30.3	2340 / 62.7	2800 / 75.0		
	80	5.5	1440 / 38.6	2800 / 75.0			
	100	6.9	1760 / 47.2	3100 / 83.1			
125	8.6	2150 / 57.6					
28-inches w.c. / 70 mbar 20 to 35-inches w.c. / 50 to 87 mbar ± 2% ABS	2	0.14	150 / 4.0	310 / 8.3	470 / 12.6	710 / 19.0	970 / 26.0
	3	0.21	180 / 4.8	390 / 10.5	590 / 15.8	940 / 25.2	1290 / 34.6
	5	0.34	250 / 6.7	530 / 14.2	840 / 22.5	1380 / 37.0	1710 / 45.8
	10	0.69	360 / 9.7	810 / 21.7	1320 / 35.4	2060 / 55.2	2500 / 67.0
	15	1.0	430 / 11.5	1010 / 27.1	1750 / 46.9	2550 / 68.3	3030 / 81.2
	20	1.4	530 / 14.2	1200 / 32.2	2130 / 57.1	2930 / 78.5	3380 / 90.6
	30	2.1	670 / 18.0	1570 / 42.1	2790 / 74.8	2550 / 68.3	
	40	2.8	830 / 22.2	1920 / 51.5	3400 / 91.1		
	50	3.5	970 / 26.0	2280 / 61.1	3800 / 102		
	60	4.1	1130 / 30.3	2630 / 70.5	4050 / 109		
	80	5.5	1440 / 38.6	3330 / 89.2			
	100	6.9	1760 / 47.2	4050 / 109			
125	8.6	2150 / 57.6					
2 psig / 0.14 bar 1.25 to 2.2 psig / 0.09 to 0.15 to bar ± 1% ABS	3	0.21	120 / 3.2	190 / 5.1	250 / 6.7	330 / 8.8	450 / 12.1
	5	0.34	150 / 4.0	270 / 7.2	360 / 9.7	560 / 15.0	750 / 20.1
	10	0.69	250 / 6.7	430 / 11.5	620 / 16.6	1020 / 27.3	1340 / 35.9
	15	1.0	330 / 8.8	600 / 16.1	800 / 21.4	1350 / 36.2	1600 / 42.9
	20	1.4	410 / 11.0	740 / 19.8	1040 / 27.9	1580 / 42.3	2040 / 54.7
	30	2.1	560 / 15.0	1050 / 28.1	1350 / 36.2	1980 / 53.1	
	40	2.8	730 / 19.6	1320 / 35.4	1790 / 48.0		
	50	3.5	870 / 23.3	1620 / 43.4	1960 / 52.5		
	60	4.1	1030 / 27.6	1910 / 51.2	2140 / 57.4		
	80	5.5	1350 / 36.2	2350 / 63.0			
	100	6.9	1650 / 44.2	2600 / 69.7			
	125	8.6	2000 / 53.6				
2 psig / 0.14 bar 1.25 to 2.2 psig / 0.09 to 0.15 bar ± 2% ABS	3	0.21	150 / 4.0	270 / 7.2	420 / 11.3	600 / 16.1	790 / 21.2
	5	0.34	210 / 5.6	420 / 11.3	620 / 16.6	960 / 25.7	1230 / 33.0
	10	0.69	340 / 9.1	700 / 18.8	1050 / 28.1	1650 / 44.2	2000 / 53.6
	15	1.0	440 / 11.8	940 / 25.2	1450 / 38.9	2130 / 57.1	2580 / 69.1
	20	1.4	520 / 13.9	1150 / 30.8	1750 / 46.9	2600 / 69.7	2980 / 79.9
	30	2.1	670 / 18.0	1540 / 41.3	2290 / 61.4	3180 / 85.2	
	40	2.8	830 / 22.2	1880 / 50.4	2740 / 73.4		
	50	3.5	970 / 26.0	2220 / 59.5	2310 / 61.9		
	60	4.1	1130 / 30.3	2600 / 69.7	3600 / 96.5		
	80	5.5	1450 / 38.9	3340 / 89.5			
	100	6.9	1750 / 46.9	4000 / 107			
	125	8.6	2100 / 56.3				

Gray areas indicate capacities limited by either droop or boost.
Blank areas indicate where maximum operating inlet pressure is exceeded for a given orifice.

Bulletin 71.1:HSR

Table 11. 3/4 NPT Angle Body Capacities

OUTLET PRESSURE SETTING, SPRING RANGE, DROOP, AND BOOST	INLET PRESSURE		CAPACITIES IN SCFH / Nm ³ /h OF 0.6 SPECIFIC GRAVITY NATURAL GAS				
			Orifice Size, Inches / mm				
	psig	bar	1/8 / 3.2	3/16 / 4.8	1/4 / 6.4	3/8 / 9.5	1/2 / 13
5-inches w.c. / 12 mbar 4 to 6-inches w.c. / 10 to 15 mbar 1-inch w.c. droop 2-inches w.c. boost	0.5	0.03	----	----	190 / 5.1	240 / 6.4	285 / 7.6
	1	0.07	95 / 2.6	220 / 5.9	250 / 6.7	330 / 8.8	400 / 10.7
	2	0.14	150 / 4.0	250 / 6.7	335 / 9.0	490 / 13.1	650 / 17.4
	3	0.21	185 / 5.0	290 / 7.8	430 / 11.5	600 / 16.1	750 / 20.1
	5	0.34	235 / 6.3	400 / 10.7	580 / 15.5	900 / 24.1	1100 / 29.5
	10	0.69	325 / 8.7	775 / 20.8	1050 / 28.1	1200 / 32.2	
	15	1.0	420 / 11.3	980 / 26.3	1295 / 34.7		
	20	1.4	500 / 13.4	1120 / 30.0	1380 / 37.0		
	30	2.1	655 / 17.6	1475 / 39.5			
	40	2.8	820 / 22.0	1785 / 47.8			
	50	3.5	945 / 25.3	2150 / 57.6			
	60	4.1	1100 / 29.5				
	80	5.5	1400 / 37.5				
100	6.9	1700 / 45.6					
7-inches w.c. / 17 mbar 6 to 8-inches w.c. / 15 to 20 mbar 1-inch w.c. droop 2-inches w.c. boost	0.5	0.03	70 / 1.9	120 / 3.2	170 / 4.6	240 / 6.4	300 / 8.0
	1	0.07	100 / 2.7	180 / 4.8	240 / 6.4	340 / 9.1	430 / 11.5
	2	0.14	130 / 3.5	250 / 6.7	330 / 8.8	510 / 13.7	630 / 16.9
	3	0.21	170 / 4.6	340 / 9.1	420 / 11.3	680 / 18.2	770 / 20.6
	5	0.34	220 / 5.9	420 / 11.3	650 / 17.4	900 / 24.1	960 / 25.7
	10	0.69	330 / 8.8	730 / 19.6	1100 / 29.5	1310 / 35.1	1310 / 35.1
	15	1.0	430 / 11.5	1000 / 26.8	1380 / 37.0	1520 / 40.7	1520 / 40.7
	20	1.4	530 / 14.2	1200 / 32.2	1560 / 41.8	1620 / 43.4	1620 / 43.4
	30	2.1	680 / 18.2	1550 / 41.5	1840 / 49.3	1750 / 46.9	
	40	2.8	850 / 22.8	1900 / 50.9	1950 / 52.3		
	50	3.5	970 / 26.0	2200 / 59.0	2000 / 53.6		
	60	4.1	1150 / 30.8	2280 / 61.1	2100 / 56.3		
	80	5.5	1450 / 38.7	2350 / 63.0			
	100	6.9	1750 / 46.9	1900 / 50.9			
125	8.6	2100 / 56.3					
9-inches w.c. / 22 mbar 8 to 10-inches w.c. / 20 to 25 mbar 1-inch w.c. droop 2-inches w.c. boost	1	0.07	----	140 / 3.8	170 / 4.6	240 / 6.4	325 / 8.7
	2	0.14	125 / 3.4	190 / 5.1	225 / 6.0	345 / 9.3	475 / 12.7
	3	0.21	190 / 5.1	220 / 5.9	270 / 7.2	475 / 12.7	660 / 17.7
	5	0.34	210 / 5.6	275 / 7.4	400 / 10.7	685 / 18.4	880 / 23.6
	10	0.69	280 / 7.5	440 / 11.8	710 / 19.0	1235 / 33.1	1215 / 32.6
	15	1.0	370 / 9.9	685 / 18.4	1235 / 33.1	1400 / 37.5	1400 / 37.5
	20	1.4	485 / 13.0	945 / 25.3	1475 / 39.5	1540 / 41.3	1500 / 40.2
	30	2.1	680 / 18.2	1475 / 39.5	1800 / 48.2	1690 / 45.3	
	40	2.8	835 / 22.4	1770 / 47.4	1925 / 51.6		
	50	3.5	990 / 26.5	2000 / 53.6	1960 / 52.5		
	60	4.1	1135 / 30.4	2155 / 57.7	2050 / 54.9		
	80	5.5	1440 / 38.6	2265 / 60.7			
	100	6.9	1750 / 46.9	2100 / 56.3			
125	8.6	2120 / 56.8					

Gray areas indicate capacities limited by either droop or boost.
 Blank areas indicate where maximum operating inlet pressure is exceeded for a given orifice.

- continued -

Table 11. 3/4 NPT Angle Body Capacities (continued)

OUTLET PRESSURE SETTING, SPRING RANGE, DROOP, AND BOOST	INLET PRESSURE		CAPACITIES IN SCFH / Nm ³ /h OF 0.6 SPECIFIC GRAVITY NATURAL GAS				
			Orifice Size, Inches / mm				
	psig	bar	1/8 / 3.2	3/16 / 4.8	1/4 / 6.4	3/8 / 9.5	1/2 / 13
11-inches w.c. / 27 mbar 10 to 12.5-inches w.c. / 25 to 31 mbar 1-inch w.c. droop 2-inches w.c. boost	1	0.07	80 / 2.1	150 / 4.0	200 / 5.4	240 / 6.4	330 / 8.8
	2	0.14	120 / 3.2	200 / 5.4	270 / 7.2	420 / 11.3	530 / 14.2
	3	0.21	150 / 4.0	250 / 6.7	350 / 9.4	530 / 14.2	680 / 18.2
	5	0.34	190 / 5.1	340 / 9.1	480 / 12.9	770 / 20.6	860 / 23.1
	10	0.69	290 / 7.8	550 / 14.7	910 / 24.4	1210 / 32.4	1210 / 32.4
	15	1.0	400 / 10.7	840 / 22.5	1210 / 32.4	1380 / 37.0	1380 / 37.0
	20	1.4	480 / 12.9	1140 / 30.6	1550 / 41.5	1590 / 42.6	1590 / 42.6
	30	2.1	670 / 18.0	1530 / 41.0	1830 / 49.0	1780 / 47.7	
	40	2.8	820 / 22.0	1970 / 52.8	1950 / 52.3		
	50	3.5	970 / 26.0	2150 / 57.6	1990 / 53.3		
	60	4.1	1120 / 30.0	2260 / 60.6	2050 / 54.9		
	80	5.5	1420 / 38.1	2390 / 64.1			
	100	6.9	1730 / 46.4	1950 / 52.3			
125	8.6	2110 / 56.6					
14-inches w.c. / 35 mbar 12.5 to 20-inches w.c. / 31 to 50 mbar 2-inches w.c. droop 2-inches w.c. boost	1	0.07	80 / 2.1	140 / 3.8	190 / 5.1	290 / 7.8	330 / 8.8
	2	0.14	120 / 3.2	230 / 6.2	300 / 8.0	430 / 11.5	570 / 15.3
	3	0.21	160 / 4.3	290 / 7.8	360 / 9.7	580 / 15.5	730 / 19.6
	5	0.34	210 / 5.6	360 / 9.7	500 / 13.4	760 / 20.4	970 / 26.0
	10	0.69	320 / 8.6	570 / 15.3	890 / 23.9	1190 / 31.9	1290 / 34.6
	15	1.0	410 / 11.0	820 / 22.0	1210 / 32.4	1460 / 39.1	1560 / 41.8
	20	1.4	500 / 13.4	1050 / 28.1	1440 / 38.6	1660 / 44.5	1700 / 45.6
	30	2.1	670 / 18.0	1500 / 40.2	1790 / 48.0	1850 / 49.6	
	40	2.8	830 / 22.2	1830 / 49.0	2020 / 54.1		
	50	3.5	970 / 26.0	2100 / 56.3	2100 / 56.3		
	60	4.1	1140 / 30.6	2120 / 56.8	2180 / 58.4		
	80	5.5	1440 / 38.6	2220 / 59.5			
	100	6.9	1770 / 47.4	2250 / 60.3			
125	8.6	2140 / 57.4					
28-inches w.c. / 70 mbar 20 to 35-inches w.c. / 50 to 87 mbar ± 1% ABS	2	0.14	120 / 3.2	250 / 6.7	310 / 8.3	420 / 11.3	570 / 15.3
	3	0.21	150 / 4.0	280 / 7.5	380 / 10.2	570 / 15.3	770 / 20.6
	5	0.34	220 / 5.9	380 / 10.2	550 / 14.7	830 / 22.2	1040 / 27.9
	10	0.69	330 / 8.8	600 / 16.1	890 / 23.9	1310 / 35.1	1570 / 42.1
	15	1.0	410 / 11.0	810 / 21.7	1220 / 32.7	1600 / 42.9	1860 / 49.9
	20	1.4	510 / 13.7	1020 / 27.3	1490 / 39.9	1790 / 48.0	2020 / 54.1
	30	2.1	660 / 17.7	1440 / 38.6	1820 / 48.8	2100 / 56.3	
	40	2.8	830 / 22.2	1800 / 48.2	2080 / 55.7		
	50	3.5	970 / 26.0	1980 / 53.1	2280 / 61.1		
	60	4.1	1130 / 30.3	2320 / 62.2	2380 / 63.8		
	80	5.5	1440 / 38.6	2400 / 64.3			
	100	6.9	1760 / 47.1	2500 / 67.0			
	125	8.6	2150 / 57.6				

Gray areas indicate capacities limited by either droop or boost.
 Blank areas indicate where maximum operating inlet pressure is exceeded for a given orifice.

- continued -

Bulletin 71.1:HSR

Table 11. 3/4 NPT Angle Body Capacities (continued)

OUTLET PRESSURE SETTING, SPRING RANGE, DROOP, AND BOOST	INLET PRESSURE		CAPACITIES IN SCFH / Nm ³ /h OF 0.6 SPECIFIC GRAVITY NATURAL GAS				
			Orifice Size, Inches / mm				
	psig	bar	1/8 / 3.2	3/16 / 4.8	1/4 / 6.4	3/8 / 9.5	1/2 / 13
28-inches w.c. / 70 mbar 20 to 35-inches w.c. / 50 to 87 mbar ± 2% ABS	2	0.14	150 / 4.0	310 / 8.3	470 / 12.6	710 / 19.0	930 / 24.9
	3	0.21	180 / 4.8	390 / 10.5	590 / 15.8	940 / 25.2	1230 / 33.0
	5	0.34	250 / 6.7	530 / 14.2	840 / 22.5	1290 / 34.6	1600 / 42.9
	10	0.69	360 / 9.7	810 / 21.7	1320 / 35.4	1890 / 50.7	2200 / 59.0
	15	1.0	430 / 11.5	1010 / 27.1	1650 / 44.2	2290 / 61.4	2530 / 67.8
	20	1.4	530 / 14.2	1200 / 32.2	1940 / 52.0	2490 / 66.7	2750 / 73.7
	30	2.1	670 / 18.0	1570 / 42.1	2430 / 65.1	2900 / 77.7	
	40	2.8	830 / 22.2	1920 / 51.5	2720 / 72.9		
	50	3.5	970 / 26.0	2280 / 61.1	2830 / 75.8		
	60	4.1	1130 / 30.3	2630 / 70.5	3050 / 81.7		
	80	5.5	1440 / 38.6	3050 / 81.7			
	100	6.9	1760 / 47.2	3150 / 84.4			
125	8.6	2150 / 57.6					
2 psig / 0.14 bar 1.25 to 2.2 psig / 0.09 to 0.15 bar ± 1% ABS	3	0.21	120 / 3.2	190 / 5.1	250 / 6.7	330 / 8.8	450 / 12.1
	5	0.34	150 / 4.0	270 / 7.2	360 / 9.7	560 / 15.0	750 / 20.1
	10	0.69	250 / 6.7	430 / 11.5	620 / 16.6	1020 / 27.3	1340 / 35.9
	15	1.0	330 / 8.8	600 / 16.1	800 / 21.4	1350 / 36.2	1480 / 39.7
	20	1.4	410 / 11.0	740 / 19.8	1040 / 27.9	1540 / 41.3	1800 / 48.2
	30	2.1	560 / 15.0	1050 / 28.1	1450 / 38.9	1850 / 49.6	
	40	2.8	730 / 19.6	1320 / 35.4	1640 / 44.0		
	50	3.5	870 / 23.3	1620 / 43.4	1900 / 50.9		
	60	4.1	1030 / 27.6	1910 / 51.2	2140 / 57.4		
	80	5.5	1350 / 36.2	2090 / 56.0			
	100	6.9	1650 / 44.2	2180 / 58.4			
	125	8.6	2000 / 53.6				
2 psig / 0.14 bar 1.25 to 2.2 psig / 0.09 to 0.15 bar ± 2% ABS	3	0.21	150 / 4.0	270 / 7.2	420 / 11.3	600 / 16.1	790 / 21.2
	5	0.34	210 / 5.6	420 / 11.3	620 / 16.6	960 / 25.7	1230 / 33.0
	10	0.69	340 / 9.1	700 / 18.8	1050 / 28.1	1430 / 38.3	1880 / 50.4
	15	1.0	440 / 11.8	940 / 25.2	1350 / 36.2	1880 / 50.4	2230 / 59.8
	20	1.4	520 / 13.9	1150 / 30.8	1620 / 43.4	2260 / 60.6	2540 / 68.1
	30	2.1	670 / 18.0	1540 / 41.3	2110 / 56.6	2520 / 67.5	
	40	2.8	830 / 22.2	1880 / 50.4	2430 / 65.1		
	50	3.5	970 / 26.0	2170 / 58.2	2640 / 70.8		
	60	4.1	1130 / 30.2	2460 / 65.9	2850 / 76.4		
	80	5.5	1450 / 38.9	2850 / 76.4			
	100	6.9	1750 / 46.9	3000 / 80.4			
	125	8.6	2100 / 56.3				

Blank areas indicate where maximum operating inlet pressure is exceeded for a given orifice.

Table 12. 3/4 x 1 NPT Angle Body Capacities

OUTLET PRESSURE SETTING, SPRING RANGE, DROOP, AND BOOST	INLET PRESSURE		CAPACITIES IN SCFH / Nm ³ /h OF 0.6 SPECIFIC GRAVITY NATURAL GAS				
			Orifice Size, Inches / mm				
	psig	bar	1/8 / 3.2	3/16 / 4.8	1/4 / 6.4	3/8 / 9.5	1/2 / 13
5-inches w.c. / 12 mbar 4 to 6-inches w.c. / 10 to 15 mbar 1-inch w.c. droop 2-inches w.c. boost	0.5	0.03			190 / 5.1	240 / 6.4	285 / 7.6
	1	0.07	110 / 3.0	220 / 5.9	250 / 6.7	355 / 9.5	450 / 12.1
	2	0.14	170 / 4.6	250 / 6.7	340 / 9.1	490 / 13.1	770 / 20.6
	3	0.21	210 / 5.6	340 / 9.1	500 / 13.4	750 / 20.1	1000 / 26.8
	5	0.34	245 / 6.6	400 / 10.7	750 / 20.1	1190 / 31.9	1330 / 35.6
	10	0.69	375 / 10.1	785 / 21.0	1290 / 34.6	1585 / 42.5	
	15	1.0	475 / 12.7	995 / 26.7	1590 / 42.6		
	20	1.4	565 / 15.1	1160 / 31.1	1850 / 49.6		
	30	2.1	740 / 19.8	1475 / 39.5			
	40	2.8	900 / 24.1	1840 / 49.3			
	50	3.5	1050 / 28.1	2180 / 58.4			
	60	4.1	1215 / 32.6				
	80	5.5	1555 / 41.7				
100	6.9	1880 / 50.4					
9-inches w.c. / 22 mbar 8 to 10-inches w.c. / 20 to 25 mbar 1-inch w.c. droop 2-inches w.c. boost	1	0.07		150 / 4.0	170 / 4.6	240 / 6.4	325 / 8.7
	2	0.14	125 / 3.4	190 / 5.1	225 / 6.0	345 / 9.3	475 / 12.7
	3	0.21	195 / 5.2	220 / 5.9	270 / 7.2	475 / 12.7	660 / 17.7
	5	0.34	210 / 5.6	275 / 7.4	400 / 10.7	685 / 18.4	880 / 23.6
	10	0.69	280 / 7.5	440 / 11.8	710 / 19.0	1235 / 33.1	1250 / 33.5
	15	1.0	370 / 9.9	685 / 18.4	1360 / 36.4	1585 / 42.5	1400 / 37.5
	20	1.4	485 / 13.0	945 / 25.3	1610 / 43.1	1820 / 48.8	1540 / 41.3
	30	2.1	680 / 18.2	1485 / 39.8	2080 / 55.7	2110 / 56.6	
	40	2.8	885 / 23.7	1840 / 49.3	2300 / 61.6		
	50	3.5	1050 / 28.1	2150 / 57.6	2760 / 74.0		
	60	4.1	1215 / 32.6	2475 / 66.3	3115 / 83.5		
	80	5.5	1530 / 41.0	3150 / 84.4			
	100	6.9	1855 / 49.7	2900 / 77.7			
125	8.6	2300 / 61.6					

Blank areas indicate where maximum operating inlet pressure is exceeded for a given orifice.
 Dark Gray areas show where indicated droop/boost would be exceeded regardless of capacity.
 Light Gray areas indicate capacities limited by either droop or boost.

Bulletin 71.1:HSR

Table 13. 1 NPT Angle Body Capacities

OUTLET PRESSURE SETTING, SPRING RANGE, DROOP, AND BOOST	INLET PRESSURE		CAPACITIES IN SCFH / Nm ³ /h OF 0.6 SPECIFIC GRAVITY NATURAL GAS				
			Orifice Size, Inches / mm				
	psig	bar	1/8 / 3.2	3/16 / 4.8	1/4 / 6.4	3/8 / 9.5	1/2 / 13
7-inches w.c. / 17 mbar 6 to 8-inches w.c. / 15 to 20 mbar 1-inch w.c. droop 2-inches w.c. boost	0.5	0.03	70 / 1.9	120 / 3.2	170 / 4.6	240 / 6.4	300 / 8.0
	1	0.07	100 / 2.7	180 / 4.8	240 / 6.4	340 / 9.1	430 / 11.5
	2	0.14	130 / 3.5	250 / 6.7	330 / 8.8	510 / 13.7	630 / 16.9
	3	0.21	170 / 4.6	340 / 9.1	420 / 11.3	680 / 18.2	860 / 23.1
	5	0.34	220 / 5.9	420 / 11.3	650 / 17.4	1030 / 27.6	1130 / 30.3
	10	0.69	330 / 8.8	730 / 19.6	1100 / 29.5	1560 / 41.8	1520 / 40.7
	15	1.0	430 / 11.5	1000 / 26.8	1560 / 41.8	1830 / 49.0	1820 / 48.8
	20	1.4	530 / 14.2	1200 / 32.2	2220 / 59.5	2270 / 60.8	2370 / 63.5
	30	2.1	680 / 18.2	1550 / 41.5	2880 / 77.2	2770 / 74.2	
	40	2.8	850 / 22.8	1900 / 50.9	3550 / 95.1		
	50	3.5	970 / 26.0	2200 / 59.0	4000 / 107		
	60	4.1	1150 / 30.8	2280 / 61.1	4200 / 113		
	80	5.5	1450 / 38.7	2350 / 63.0			
	100	6.9	1750 / 46.9	1900 / 50.9			
125	8.6	2100 / 56.3					
11-inches w.c. / 27 mbar 10 to 12.5-inches w.c. / 25 to 31 mbar 1-inch w.c. droop 2-inches w.c. boost	1	0.07	80 / 2.1	150 / 4.0	200 / 5.4	240 / 6.4	330 / 8.8
	2	0.14	120 / 3.2	200 / 5.4	270 / 7.2	420 / 11.3	530 / 14.2
	3	0.21	150 / 4.0	250 / 6.7	350 / 9.4	530 / 14.2	680 / 18.2
	5	0.34	190 / 5.1	340 / 9.1	480 / 12.9	770 / 20.6	970 / 26.0
	10	0.69	290 / 7.8	550 / 14.7	1050 / 28.1	1230 / 33.0	1430 / 38.3
	15	1.0	400 / 10.7	840 / 22.5	1470 / 39.4	1750 / 46.9	1760 / 47.2
	20	1.4	480 / 12.9	1140 / 30.6	1920 / 51.5	2230 / 59.8	2450 / 65.7
	30	2.1	670 / 18.0	1530 / 41.0	2430 / 65.1	2900 / 77.7	
	40	2.8	820 / 22.0	1970 / 52.8	2870 / 76.9		
	50	3.5	970 / 26.0	2150 / 57.6	3420 / 91.7		
	60	4.1	1120 / 30.0	2260 / 60.6	3750 / 101		
	80	5.5	1420 / 38.1	2390 / 64.1			
	100	6.9	1730 / 46.4	1950 / 52.3			
	125	8.6	2110 / 56.6				
14-inches w.c. / 35 mbar 12.5 to 20-inches w.c. / 31 to 50 mbar 2-inches w.c. droop 2-inches w.c. boost	1	0.07	80 / 2.1	140 / 3.8	190 / 5.1	290 / 7.8	330 / 8.8
	2	0.14	120 / 3.2	230 / 6.2	300 / 8.0	430 / 11.5	570 / 15.3
	3	0.21	160 / 4.3	290 / 7.8	360 / 9.7	580 / 15.5	730 / 19.6
	5	0.34	210 / 5.6	360 / 9.7	500 / 13.4	760 / 20.4	1000 / 26.8
	10	0.69	320 / 8.6	570 / 15.3	890 / 23.9	1290 / 34.6	1480 / 39.7
	15	1.0	410 / 11.0	820 / 22.0	1210 / 32.4	1570 / 42.1	1760 / 47.2
	20	1.4	500 / 13.4	1050 / 28.1	1510 / 40.5	1800 / 48.2	2400 / 64.3
	30	2.1	670 / 18.0	1500 / 40.2	1980 / 53.1	2430 / 65.1	
	40	2.8	830 / 22.2	1880 / 50.4	2250 / 60.3		
	50	3.5	970 / 26.0	2190 / 58.7	2570 / 68.9		
	60	4.1	1140 / 30.6	2450 / 65.7	3400 / 91.1		
	80	5.5	1440 / 38.6	3390 / 90.9			
	100	6.9	1770 / 47.4	2600 / 69.7			
	125	8.6	2140 / 57.4				

Gray areas indicate capacities limited by either droop or boost.
 Blank areas indicate where maximum operating inlet pressure is exceeded for a given orifice.

- continued -

Table 13. 1 NPT Angle Body Capacities (continued)

OUTLET PRESSURE SETTING, SPRING RANGE, DROOP, AND BOOST	INLET PRESSURE		CAPACITIES IN SCFH / Nm ³ /h OF 0.6 SPECIFIC GRAVITY NATURAL GAS				
			Orifice Size, Inches / mm				
	psig	bar	1/8 / 3.2	3/16 / 4.8	1/4 / 6.4	3/8 / 9.5	1/2 / 13
28-inches w.c. / 70 mbar 20 to 35-inches w.c. / 50 to 87 mbar ± 1% ABS	2	0.14	120 / 3.2	250 / 6.7	310 / 8.3	420 / 11.3	570 / 15.3
	3	0.21	150 / 4.0	280 / 7.5	380 / 10.2	570 / 15.3	770 / 20.6
	5	0.34	220 / 5.9	380 / 10.2	550 / 14.7	830 / 22.2	1150 / 30.8
	10	0.69	330 / 8.8	600 / 16.1	890 / 23.9	1310 / 35.1	1700 / 45.6
	15	1.0	410 / 11.0	810 / 21.7	1220 / 32.7	1720 / 46.1	2200 / 59.0
	20	1.4	510 / 13.7	1020 / 27.3	1490 / 39.9	2100 / 56.3	2500 / 67.0
	30	2.1	660 / 17.7	1440 / 38.6	2120 / 56.8	2650 / 71.0	
	40	2.8	830 / 22.2	1800 / 48.2	2500 / 67.0		
	50	3.5	970 / 26.0	2120 / 56.8	2900 / 77.7		
	60	4.1	1130 / 30.3	2340 / 62.7	3350 / 89.8		
	80	5.5	1440 / 38.6	2800 / 75.0			
	100	6.9	1760 / 47.2	3100 / 83.1			
	125	8.6	2150 / 57.6				
28-inches w.c. / 70 mbar 20 to 35-inches w.c. / 50 to 87 mbar ± 2% ABS	2	0.14	150 / 4.0	310 / 8.3	470 / 12.6	710 / 19.0	1030 / 27.6
	3	0.21	180 / 4.8	390 / 10.5	590 / 15.8	940 / 25.2	1380 / 37.0
	5	0.34	250 / 6.7	530 / 14.2	840 / 22.5	1380 / 37.0	1850 / 49.6
	10	0.69	360 / 9.7	810 / 21.7	1320 / 35.4	2170 / 58.2	2650 / 71.0
	15	1.0	430 / 11.5	1010 / 27.1	1750 / 46.9	2800 / 75.0	3250 / 87.1
	20	1.4	530 / 14.2	1200 / 32.2	2130 / 57.1	3300 / 88.4	3650 / 97.8
	30	2.1	670 / 18.0	1570 / 42.1	2790 / 74.8	4000 / 107	
	40	2.8	830 / 22.2	1920 / 51.5	3550 / 95.1		
	50	3.5	970 / 26.0	2280 / 61.1	4150 / 111		
	60	4.1	1130 / 30.3	2630 / 70.5	4800 / 129		
	80	5.5	1440 / 38.6	3330 / 89.2			
	100	6.9	1760 / 47.2	4050 / 109			
	125	8.6	2150 / 57.6				
2 psig / 0.14 bar 1.25 to 2.2 psig / 0.09 to 0.15 to bar ± 1% ABS	3	0.21	120 / 3.2	190 / 5.1	250 / 6.7	330 / 8.8	450 / 12.1
	5	0.34	150 / 4.0	270 / 7.2	360 / 9.7	560 / 15.0	750 / 20.1
	10	0.69	250 / 6.7	430 / 11.5	620 / 16.6	1020 / 27.3	1340 / 35.9
	15	1.0	330 / 8.8	600 / 16.2	800 / 21.4	1350 / 36.2	1600 / 42.9
	20	1.4	410 / 11.0	740 / 19.8	1040 / 27.9	1700 / 45.6	2040 / 54.7
	30	2.1	560 / 15.0	1050 / 28.1	1650 / 44.2	2240 / 60.0	
	40	2.8	730 / 19.6	1320 / 35.4	1920 / 51.5		
	50	3.5	870 / 23.3	1620 / 43.4	2130 / 57.1		
	60	4.1	1030 / 27.6	1910 / 51.2	2500 / 67.0		
	80	5.5	1350 / 36.2	2350 / 63.0			
	100	6.9	1650 / 44.2	2600 / 69.7			
	125	8.6	2000 / 53.6				
	2 psig / 0.14 bar 1.25 to 2.2 psig / 0.09 to 0.15 bar ± 2% ABS	3	0.21	150 / 4.0	270 / 7.2	420 / 11.3	600 / 16.1
5		0.34	210 / 5.6	420 / 11.3	620 / 16.6	960 / 25.7	1320 / 35.4
10		0.69	340 / 9.1	700 / 18.8	1050 / 28.1	1650 / 44.2	2150 / 57.6
15		1.0	440 / 11.8	940 / 25.2	1450 / 38.9	2230 / 59.8	2720 / 72.9
20		1.4	520 / 13.9	1150 / 30.8	1750 / 46.9	2730 / 73.2	3240 / 86.8
30		2.1	670 / 18.0	1540 / 41.3	2470 / 66.2	3520 / 94.3	
40		2.8	830 / 22.2	1880 / 50.4	2930 / 78.5		
50		3.5	970 / 26.0	2220 / 59.5	3600 / 96.5		
60		4.1	1130 / 30.3	2600 / 69.7	4200 / 113		
80		5.5	1450 / 38.9	3340 / 89.5			
100		6.9	1750 / 46.9	4000 / 107			
125		8.6	2100 / 56.3				

Blank areas indicate where maximum operating inlet pressure is exceeded for a given orifice.

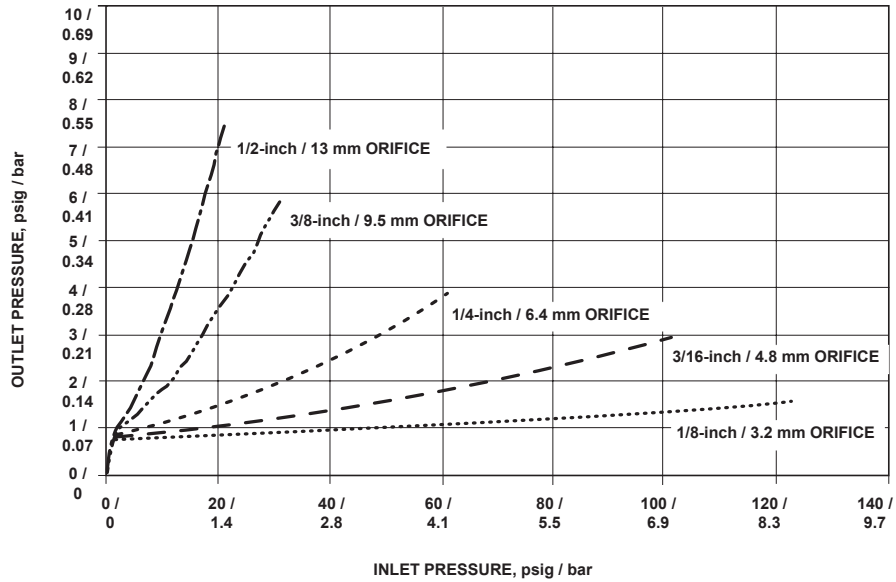

Figure 3. 7-inches w.c. / 17 mbar Setpoint Relief Curves (with Lever Disconnected, No Vent Piping, and 3/4 or 1 NPT Vent)

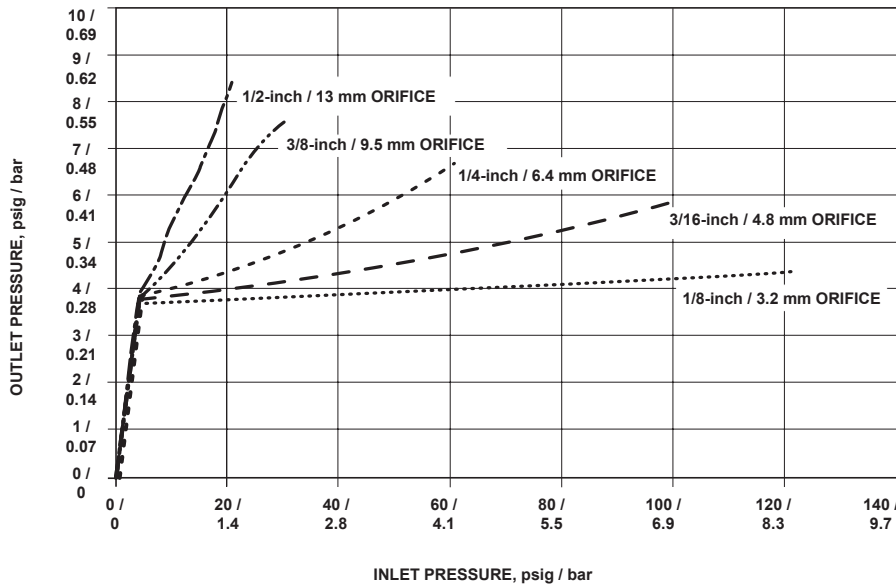

Figure 4. 2 psig / 0.14 bar Setpoint Relief Curves (with Lever Disconnected, No Vent Piping, and 3/4 or 1 NPT Vent)

Table 14. Relief Performance

ORIFICE SIZE		MAXIMUM ALLOWABLE INLET PRESSURE IF OUTLET PRESSURE IS HELD AT OR BELOW 2 psig / 140 mbar	
Inch	mm	psig	bar
1/8	3.2	125	8.6
3/16	4.8	65	4.5
1/4	6.4	30	2.1
3/8	9.5	10	0.69
1/2	13	7	0.48

The relief performance testing is in accordance with ANSI B109.4 and CSA 6.18, with the regulator set at 7-inches w.c. / 17 mbar, stem linkage disconnected, and vented directly to atmosphere using the 3/4 or 1 NPT vent.

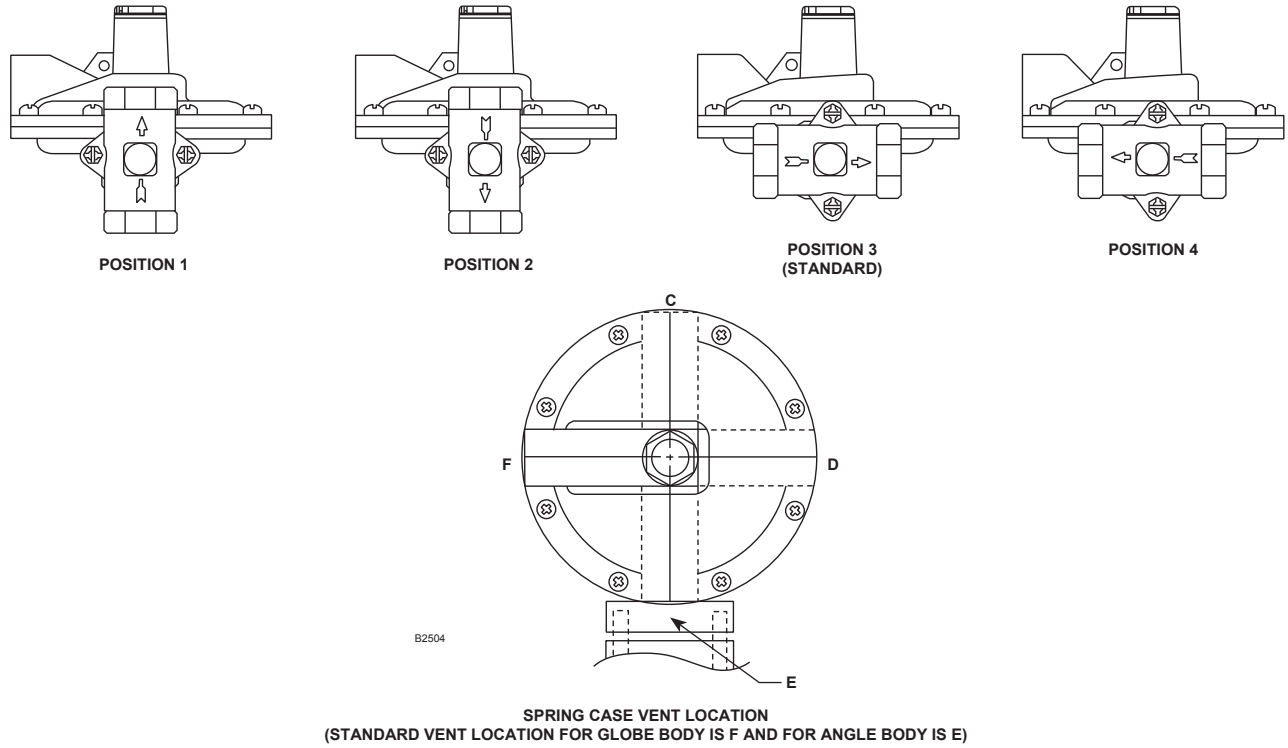
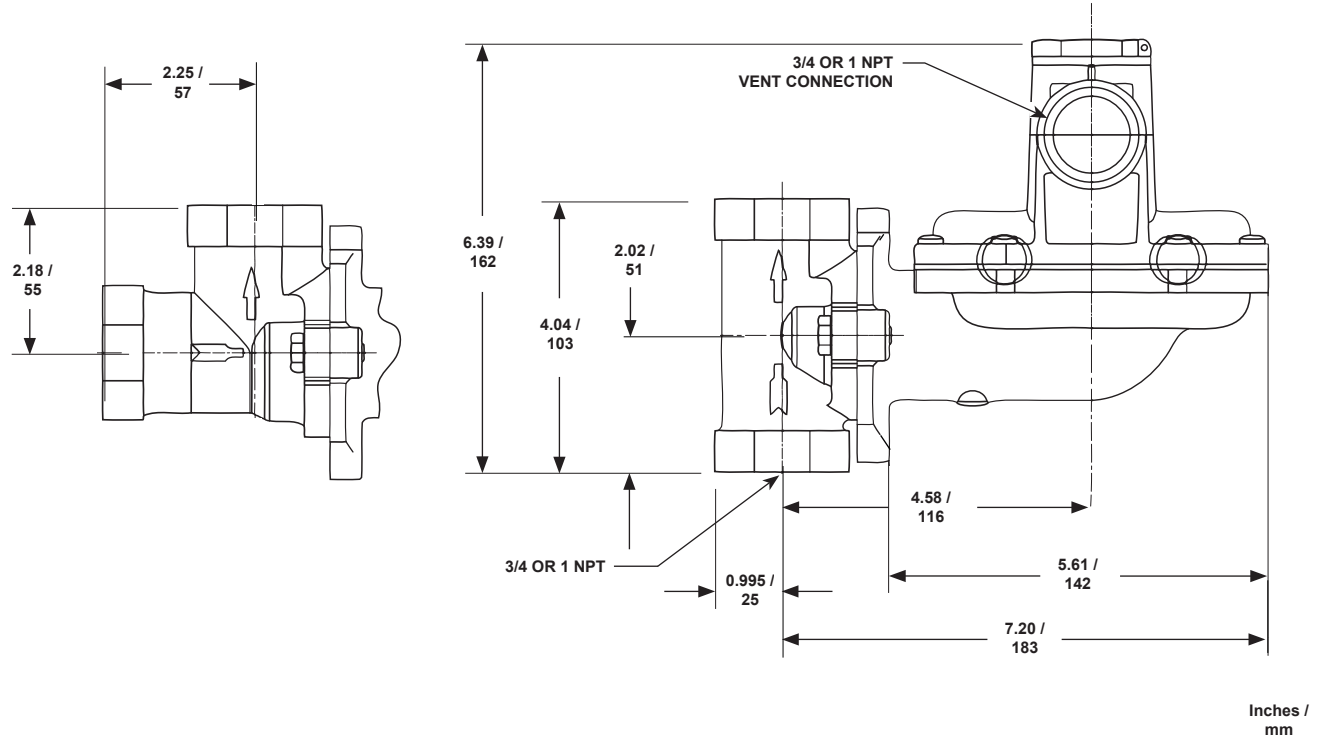

Figure 5. Regulator Body and Spring Case Vent Locations (Body Position is with Regard to the Outlet)



NOTE: THE STANDARD BODY ORIENTATION FOR THE ANGLE BODY IS WITH THE BODY OUTLET ROTATED 90 DEGREES TOWARD THE READER. COMPARED TO FIGURE 5, THE OUTLET OF THE ANGLE BODY WILL POINT IN THE SAME DIRECTION AS POSITION "3" OF A GLOBE BODY.

Figure 6. Dimensions

Bulletin 71.1:HSR

Ordering Guide

Body Type, Size and End Connection

Style (Select One)

Globe

- 3/4 NPT***
- 3/4 x 1 NPT***
- 1 NPT***

Angle

- 3/4 NPT***
- 3/4 x 1 NPT***
- 1 NPT***

Orifice Size (Select One)

- 1/8-inch / 3.2 mm***
- 3/16-inch / 4.8 mm***
- 1/4-inch / 6.4 mm***
- 3/8-inch / 9.5 mm***
- 1/2-inch / 13 mm***

Outlet Pressure Range (Select One)

- 4 to 6-inches w.c. / 10 to 15 mbar, Orange***
- 6 to 8-inches w.c. / 15 to 20 mbar, Yellow***
- 8 to 10-inches w.c. / 20 to 25 mbar, Black***
- 10 to 12.5-inches w.c. / 25 to 31 mbar, Silver***
- 12.5 to 20-inches w.c. / 31 to 50 mbar, Gray***
- 20 to 35-inches w.c. / 50 to 87 mbar, Pink***
- 1.25 to 2.2 psig / 0.09 to 0.15 bar, Light Blue***

Body Orientation (Select One)

Globe

- Position 1***
- Position 2***
- Position 3 (standard)***
- Position 4***

Angle

- Position 1***
- Position 2***
- Position 3 (standard)***
- Position 4***

Regulators Quick Order Guide	
***	Readily Available for Shipment
**	Allow Additional Time for Shipment
*	Special Order, Constructed from Non-Stocked Parts. Consult your local Sales Office for Availability.
Availability of the product being ordered is determined by the component with the longest shipping time for the requested construction.	

Vent Size (Select One)

- 3/4 NPT***
- 1 NPT***

Vent Orientation (Select One)

Globe

- Position C***
- Position D***
- Position E***
- Position F (standard)***

Angle

- Position C***
- Position D***
- Position E (standard)***
- Position F***

Specification Worksheet

Application:

Specific Use _____
 Line Size _____
 Fluid Type _____
 Specific Gravity _____
 Temperature _____

Does the Application Require Overpressure Protection?

- Yes No

Pressure:

Maximum Inlet Pressure _____
 Minimum Inlet Pressure _____
 Differential Pressure _____
 Set Pressure _____
 Maximum Flow _____

Accuracy Requirements:

Less Than or Equal To:

- 5% 10% 20% 40%

Construction Material Requirements (if known):

Industrial Regulators

Emerson Process Management Regulator Technologies, Inc.

USA - Headquarters
 McKinney, Texas 75069-1872, USA
 Tel: +1 800 558 5853
 Outside U.S. +1 972 548 3574

Asia-Pacific
 Shanghai 201206, China
 Tel: +86 21 2892 9000

Europe
 Bologna 40013, Italy
 Tel: +39 051 419 0611

Middle East and Africa
 Dubai, United Arab Emirates
 Tel: +971 4811 8100

Natural Gas Technologies

Emerson Process Management Regulator Technologies, Inc.

USA - Headquarters
 McKinney, Texas 75069-1872, USA
 Tel: +1 800 558 5853
 Outside U.S. +1 972 548 3574

Asia-Pacific
 Singapore 128461, Singapore
 Tel: +65 6770 8337

Europe
 Bologna 40013, Italy
 Tel: +39 051 419 0611
 Chartres 28008, France
 Tel: +33 2 37 33 47 00

TESCOM

Emerson Process Management Tescom Corporation

USA - Headquarters
 Elk River, Minnesota 55330-2445, USA
 Tel: +1 763 241 3238
 +1 800 447 1250

Europe
 Selmsdorf 23923, Germany
 Tel: +49 38823 31 287

Asia-Pacific
 Shanghai 201206, China
 Tel: +86 21 2892 9499

For further information visit www.fisherregulators.com

The Emerson logo is a trademark and service mark of Emerson Electric Co. All other marks are the property of their prospective owners. Fisher is a mark owned by Fisher Controls International LLC, a business of Emerson Process Management.

The contents of this publication are presented for informational purposes only, and while every effort has been made to ensure their accuracy, they are not to be construed as warranties or guarantees, express or implied, regarding the products or services described herein or their use or applicability. We reserve the right to modify or improve the designs or specifications of such products at any time without notice.

Emerson Process Management Regulator Technologies, Inc., does not assume responsibility for the selection, use or maintenance of any product. Responsibility for proper selection, use and maintenance of any Emerson Process Management Regulator Technologies, Inc. product remains solely with the purchaser.