

Case Material : Steel Painted Black
 Lens material : Polycarbonate
 Socket : Brass
 Tube : Phosphor Bronze
 Movement : Brass
 Accuracy : +/-3%-25-3%
 Ambient Temperature Limits: -40F to 158F (-40C to 70C)
 Process Temperature Limits: -40F to 158F (-40C to 70C)
 Enclosure Rating : IP52

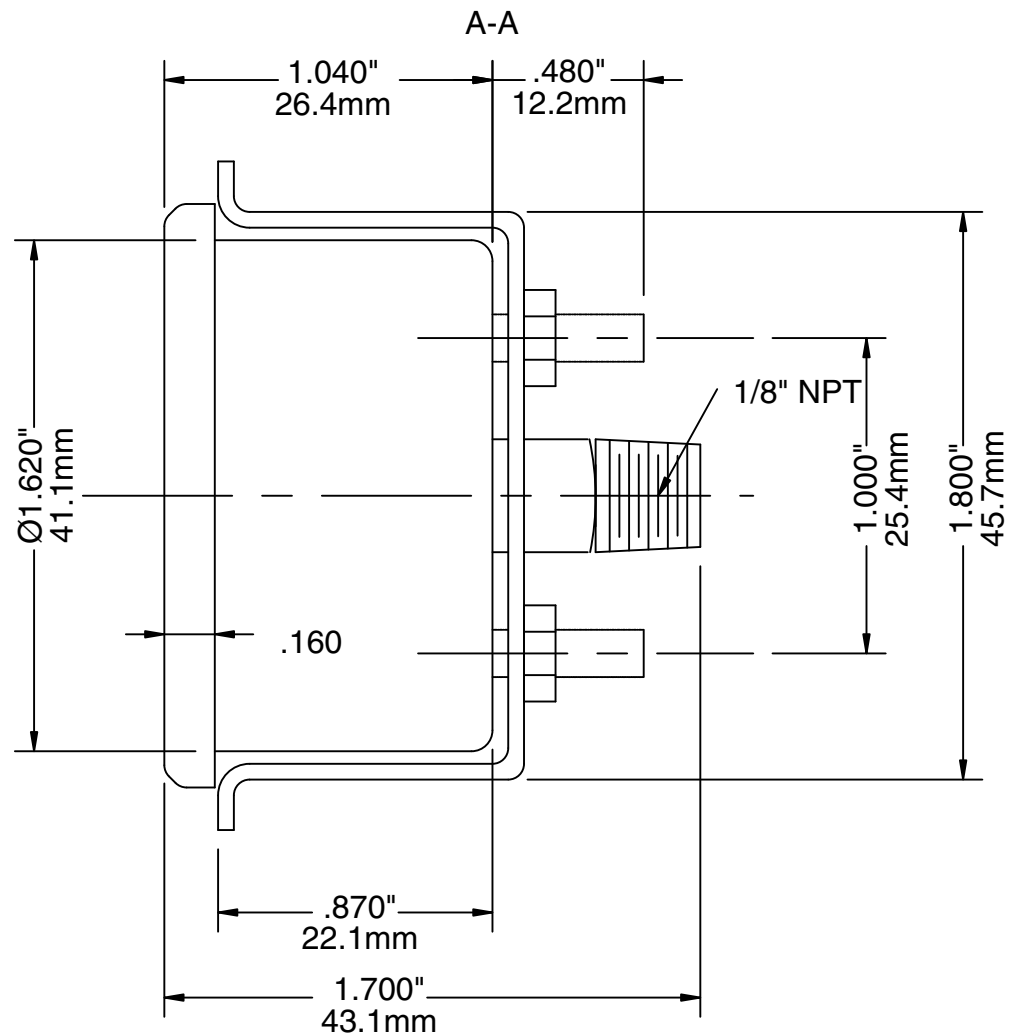
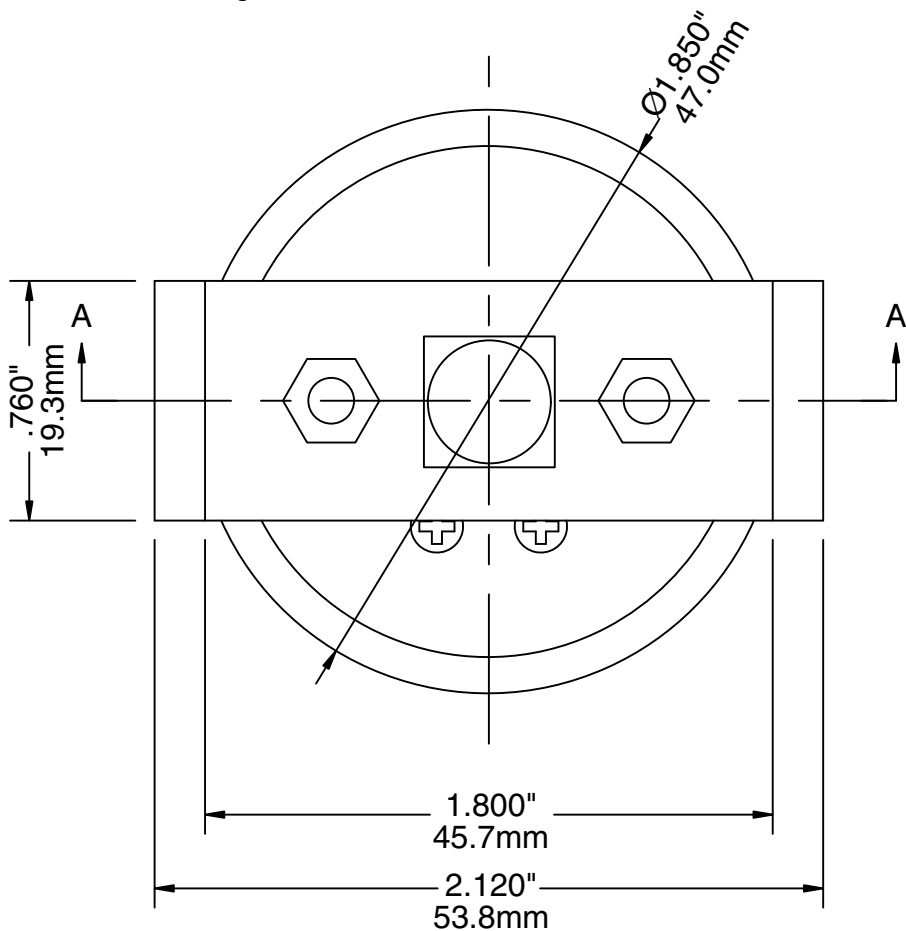

DRAWN BY: PHOEBE MA

ENG. APPROVAL:

ALL DIMENSIONS IN INCHES

TOLERANCES
(unless otherwise stated)

Fractional:	1/64"
Decimal:	0.06"

REVISION DATE: Jan. 08, 2009

TITLE:

1.5" ECONOMY PANEL MOUNTED GAUGE

DRAWING NO: PEU-15-Y-B-V