



Description & Features:

- General purpose panel mounted gauge with 1.5" (40mm) to 3.5" (90mm) dial sizes
- Flutterless pointer
- Dampened movement
- Removable lens
- Zero-adjustment
- ±2-1-2% accuracy
- CRN registered
- 5 year warranty

Applications:

- Panels, compressor equipment, water and oil pumps, where rapid pressure fluctuations or system vibration require a stable pointer

Specifications

Specifications	
Dial	1.5" (40mm), 2" (50mm), 2.5" (63mm), 3.5" (90mm), white aluminum with black and red markings
Case	Steel, painted black
Lens	Acrylic, threaded
Socket	Brass
Connection	1/8" NPT or 1/4" NPT standard
Bourdon Tube	Phosphor bronze
Movement	Brass (flutterless movement)
Pointer	Aluminum, black
Welding	Silver alloy
Over-Pressure Limit	25% of full scale value
Working Pressure	Maximum 75% of full scale value
Ambient/Process Temperature	-40°F to 150°F (-40°C to 65°C)
Accuracy	±2-1-2% ANSI/ASME Grade A
Enclosure Rating	IP52

1.5" Back Connection, U-Clamp

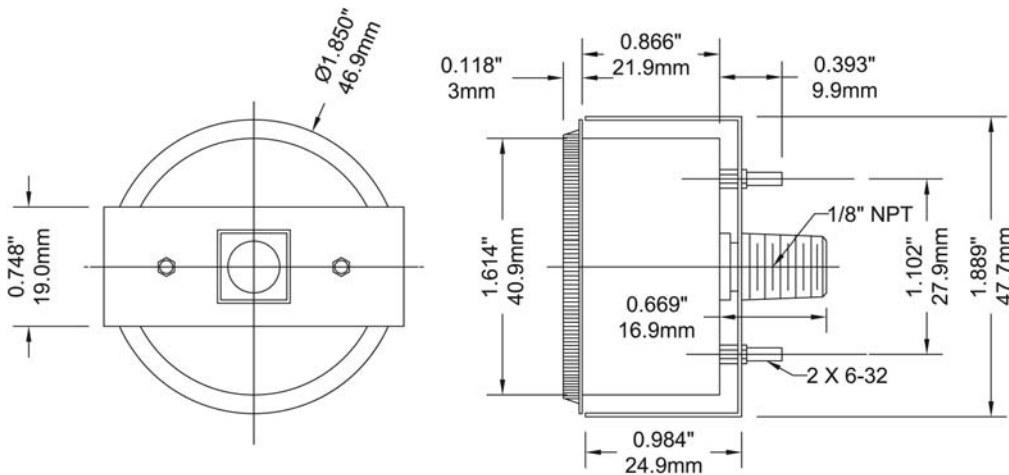

Order Codes (products in bold are normally in stock)

Dial Size	1.5" (40mm)	2" (50mm)		2.5" (63mm)	3.5" (75mm)
Connection	1/8" Centre Back	1/8" Centre Back	1/4" Centre Back	1/4" Centre Back	1/4" Centre Back
Panel Cut-out	1.69"(43mm)	2.11"(53.5mm)	2.11"(53.5mm)	2.66"(67.5mm)	3.68"(93.5mm)
Overall O.D.	1.85"(47.7mm)	2.27"(57.9mm)	2.27"(57.9mm)	2.82"(71.9mm)	3.94"(98.9mm)
30" Hg Vac/kPa	P9U901397UC	P9U901424UC	P9U901428UC	P9U901431UC	P9U901455UC
30"/0/15 psi/kPa	-	-	-	-	-
30"/0/30 psi/kPa	-	-	-	-	-
30"/0/60 psi/kPa	-	-	-	-	-
30"/0/100 psi/kPa	-	-	-	-	-
0/15 psi/kPa	P9U901399UC	P9U901425UC	P9U901429UC	P9U901436UC	P9U901464UC
0/30 psi/kPa	P9U901400UC	P9U901402UC	P9U901403UC	P9U901437UC	P9U901456UC
0/60 psi/kPa	P9U901401UC	P9U901404UC	P9U901405UC	P9U901438UC	P9U901457UC
0/100 psi/kPa	P9U901420UC	P9U901406UC	P9U901407UC	P9U901439UC	P9U901458UC
0/160 psi/kPa	P9U901421UC	P9U901408UC	P9U901409UC	P9U901440UC	P9U901459UC
0/200 psi/kPa	P9U901422UC	P9U901426UC	P9U901410UC	P9U901441UC	P9U901460UC
0/300 psi/kPa	P9U901423UC	P9U901427UC	P9U901411UC	P9U901442UC	P9U901461UC
0/400 psi/kPa	P9U901443UC	P9U901445UC	P9U901447UC	P9U901453UC	P9U901462UC
0/600 psi/kPa	P9U901444UC	P9U901446UC	P9U901448UC	P9U901454UC	P9U901463UC

Other ranges and connection sizes available upon request. For scale change, refer to How to Order Guide for scale codes.

2" Back Connection, U-Clamp

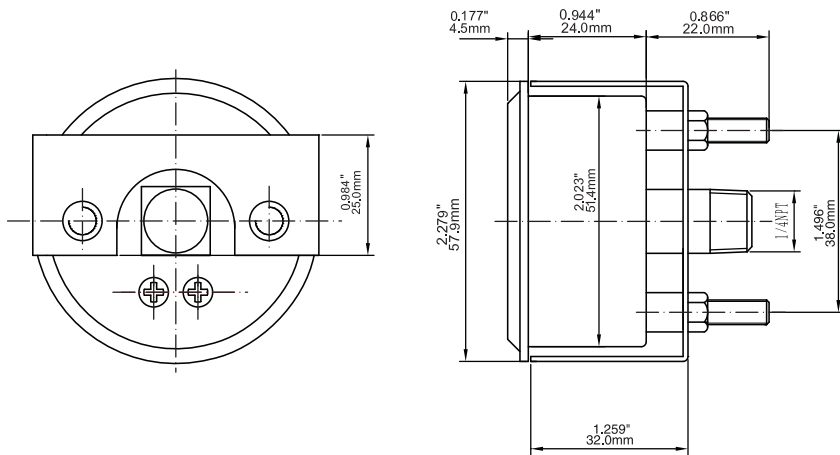

2.5" Back Connection, U-Clamp

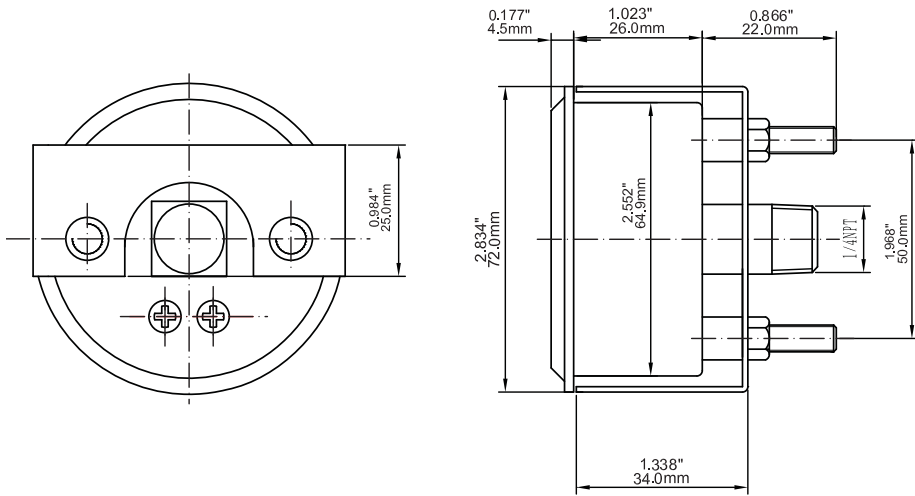

3.5" Back Connection, U-Clamp

