

Operating instructions

Solenoid valve for gas VAS 1 – 3, double solenoid valve VCS 1 – 3



Cert. version 01.14

Contents

Solenoid valve for gas VAS 1 – 3, double solenoid valve VCS 1 – 3.....	1
Contents	1
Safety.....	1
Checking the usage.....	2
Installation	2
Wiring	4
M20 cable gland	4
Plug	4
Socket.....	5
Proof of closure switch.....	5
Tightness test.....	6
Commissioning.....	6
Replacing the actuator	6
Replacing the damping unit	8
Maintenance.....	8
Accessories	9
Pressure switch for gas DG..VC.....	9
Bypass/pilot gas valves	9
Checking the bypass/pilot gas valve for tightness	11
Tightness control TC 1V.....	11
Cable gland set for double solenoid valves.....	12
Attachment block.....	12
Seal set for sizes 1–3	13
Cable gland with pressure equalization element	13
Technical data	13
Logistics	15
Certification	15
Contact	16

Safety

Please read and keep in a safe place



Please read through these instructions carefully before installing or operating. Following the installation, pass the instructions on to the operator. This unit must be installed and commissioned in accordance with the regulations and standards in force. These instructions can also be found at www.docuthek.com.

Explanation of symbols

1, 2, 3... = Action
 > = Instruction

Liability

We will not be held liable for damage resulting from non-observance of the instructions and non-compliant use.

Safety instructions

Information that is relevant for safety is indicated in the instructions as follows:

DANGER

Indicates potentially fatal situations.

WARNING

Indicates possible danger to life and limb.

! CAUTION

Indicates possible material damage.

All interventions may only be carried out by qualified gas technicians. Electrical interventions may only be carried out by qualified electricians.

Conversion, spare parts

All technical changes are prohibited. Only use OEM spare parts.

Changes to edition 02.17

The following chapters have been changed:

- Installation
- Certification

Checking the usage

Intended use

Gas solenoid valves VAS for safeguarding gas or air on various appliances. Double solenoid valves VCS are combinations of two gas solenoid valves VAS. This function is only guaranteed when used within the specified limits – see page 13 (Technical data). Any other use is considered as non-compliant.

Type code

Code	Description
VAS	Gas solenoid valve
1–3	Sizes
T	T-product
10–65	Inlet and outlet flange nominal size
R	Rp internal thread
N	NPT internal thread (ANSI/ASME)
/N	Quick opening, quick closing
/L	Slow opening, quick closing
	Mains voltage:
W	230 V AC, 50/60 Hz
Q	120 V AC, 50/60 Hz
K	24 V DC
P	100 V AC, 50/60 Hz
Y	200 V AC, 50/60 Hz
S	With visual position indicator and proof of closure switch
G	and proof of closure switch for 24 V
	Viewing side (in flow direction):
R	from the right
L	from the left
	Electrical connection:
1	plug with socket
2	plug without socket
3	M20 cable gland

Part designations

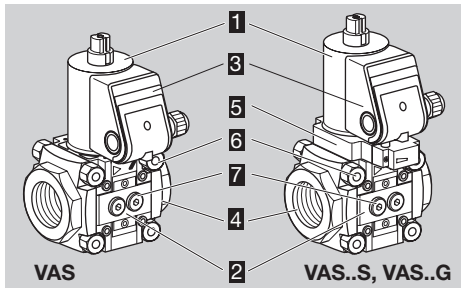

- 1** Solenoid actuator
- 2** Flow body
- 3** Connection box
- 4** Connection flange
- 5** Proof of closure switch
- 6** Connection parts
- 7** Sealing plug

Mains voltage, electrical power consumption, ambient temperature, enclosure, inlet pressure and installation position: see type label.

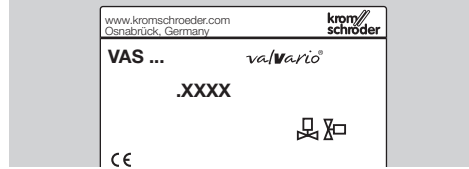

Installation

! CAUTION

Please observe the following to ensure that the gas solenoid valve is not damaged during installation and operation:

- Important! The gas must be dry in all conditions and must not contain condensate.
 - Sealing material and dirt, e.g. thread cuttings, must not be allowed to get into the valve housing.
 - A filter must be installed upstream of every system.
 - It is not permitted to install gas solenoid valve VAS downstream of flow rate regulator VAH/VRH and upstream of fine-adjusting valve VMV. The VAS would no longer be able to perform its function as a second safety valve if installed in the above-mentioned position.
 - Do not store or install the unit in the open air.
 - Dropping the device can cause permanent damage. In this event, replace the entire device and associated modules before use.
 - If more than three valVario controls are installed in line, the controls must be supported.
 - Do not clamp the unit in a vice. Only secure the flange by holding the octagon with a suitable spanner. Risk of external leakage.
 - Solenoid valves with overtravel switch and visual position indicator VAS..SR/SL: actuator cannot be rotated.
 - In the case of double solenoid valves, the position of the connection box can only be changed by removing the actuator and reinstalling it rotated by 90° or 180°.
 - Cleaning work on the solenoid actuator may not be performed using high pressure and/or chemical cleaning agents. This can cause moisture to get into the solenoid actuator and may lead to a dangerous failure.
- ▷ When joining two valves, determine the position of the connection boxes, push through the knock-outs in the connection boxes and install a cable gland set before installation in the pipe-work, see page 12 (Cable gland set for double solenoid valves).

- ▷ Install the unit in the pipe free of mechanical stress.
- ▷ For retrofitting a second gas solenoid valve, use the double block seal instead of O-rings. The double block seal is supplied with the seal set, see page 13 (Seal set for sizes 1–3).
- ▷ Installation position: black solenoid actuator in the vertical upright position or tilted up to the horizontal, not upside down.

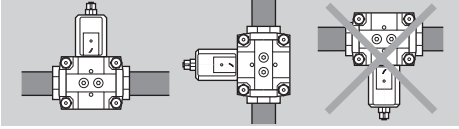

- ▷ The housing must not be in contact with masonry. Minimum clearance 20 mm (0,78").
- ▷ The inlet pressure p_u and the outlet pressure p_d can be measured using the pressure test points on both sides.

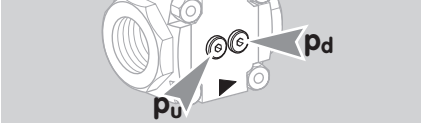

Strainer

- ▷ A strainer must be fitted in the unit on the inlet side. If two or more gas solenoid valves are installed in line, then a strainer only needs to be fitted on the inlet side of the first valve.

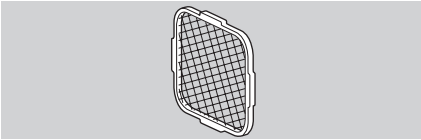

Differential pressure orifice

- ▷ If pressure regulator VAD/VAG/VAV 1 is retrofitted upstream of gas solenoid valve VAS 1, a DN 25 differential pressure orifice with outlet opening $d = 30 \text{ mm}$ (1.18") must be inserted at the outlet of the pressure regulator. In the case of pressure regulator VAX 115 or VAX 120, the DN 25 differential pressure orifice must be ordered separately and retrofitted, Order No. 74922240.
- ▷ The retaining frame must be fitted to secure the differential pressure orifice at the outlet of the regulator.

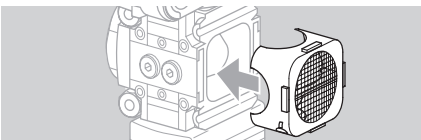

Retaining frame

- ▷ If two controls (regulators or valves) are assembled, a retaining frame with double block seal must be fitted, see page 13 (Seal set for sizes 1–3).

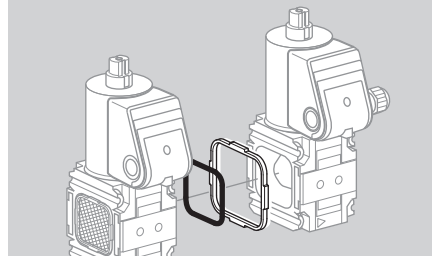

- ▷ The seals in some gas compression fittings are approved for temperatures of up to 70°C (158°F). This temperature limit will not be exceeded if the flow through the pipe is at least 1 m³/h (35.31 SCFH) of gas and the maximum ambient temperature is 50°C (122°F).

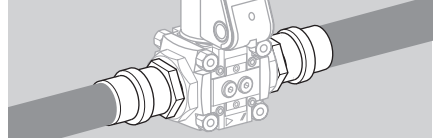

VAS with flanges

- 1 Note direction of flow.



VAS without flanges

- 1 Note direction of flow.

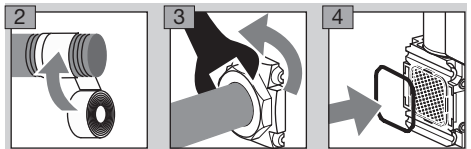

- ▷ O-ring and strainer (Fig. 4) must be fitted.

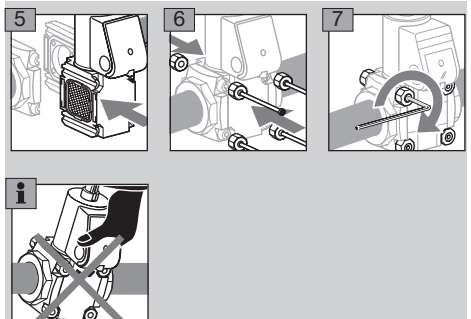

Wiring

⚠ WARNING

Attention! Please observe the following to ensure that no damage occurs:

- Electric shocks can be fatal! Before working on possible live components, ensure the unit is disconnected from the power supply.
- The solenoid actuator heats up during operation. Surface temperature approx. 85°C (approx. 185°F).



- ▷ Use temperature-resistant cable (> 90°C).

1 Disconnect the system from the electrical power supply.

2 Shut off the gas supply.

- ▷ Wiring to EN 60204-1.

▷ UL requirements for the NAFTA market. To maintain the UL environmental rating Type 2, the enclosure openings shall be closed with fittings rated UL Type 2; 3; 3R; 3RX; 3S; 3SX; 3X; 4X; 5; 6; 6P; 12; 12K or 13. Gas solenoid valves shall be protected by a branch circuit protective device not exceeding 15 A.

- ▷ When joining two valves, install a cable gland set, see page 12 (Cable gland set for double solenoid valves), between the connection boxes.

First push through the knock-out – then unscrew the cover!

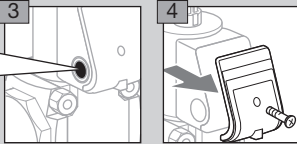

- ▷ If the M20 cable gland or plug is already fitted, it is not necessary to push through the knock-out.

M20 cable gland

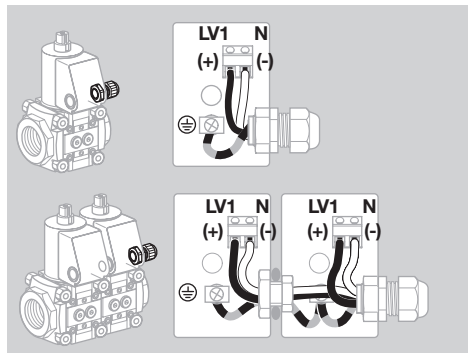
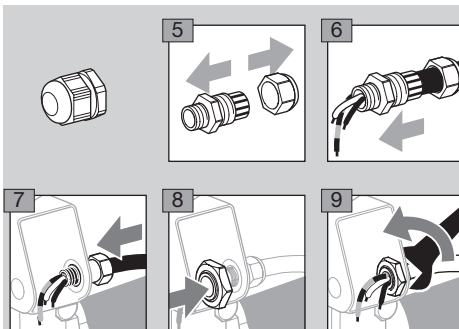

Plug

LV1_{V1} (+) = black, LV1_{V2} (+) = brown, N (-) = blue

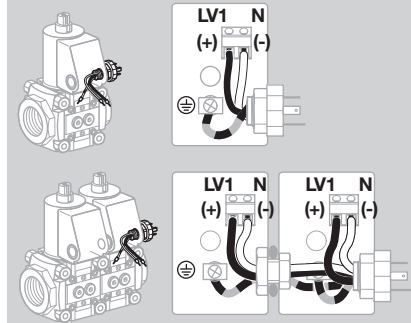
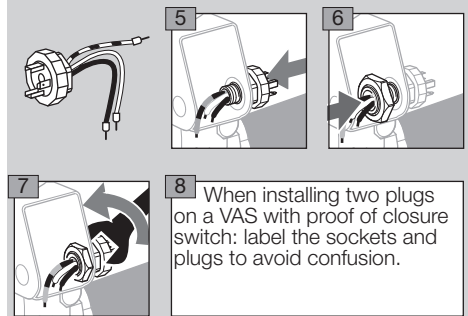

Socket

1 = N (-), 2 = LV1_{V1} (+), 3 = LV1_{V2} (+)

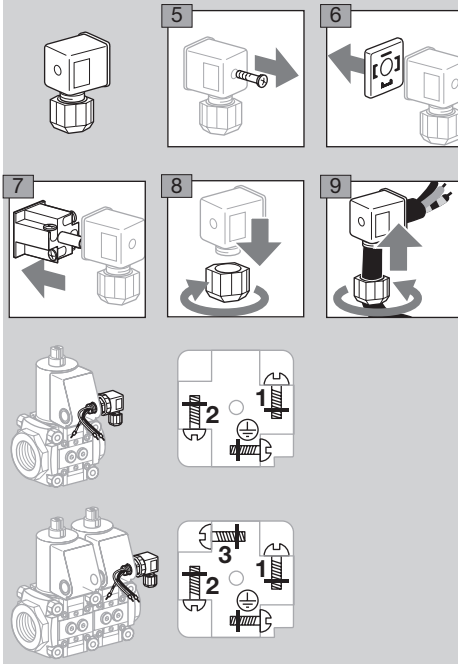

Proof of closure switch

- ▷ VAS open: contacts **1** and **2** closed, VAS closed: contacts **1** and **3** closed.
- ▷ Indicator of proof of closure switch: red = VAS closed, white = VAS open.
- ▷ Double solenoid valve: if a plug with socket is fitted, only one proof of closure switch can be connected.

! CAUTION

Please observe the following to ensure smooth operation:

- The proof of closure switch is not suitable for frequent cycling operation.
- Route valve and proof of closure switch cables separately through M20 cable glands or use two separate plugs. Otherwise, there is a risk of interference between valve voltage and proof of closure switch voltage.
- ▷ To make wiring easier, the connection terminal for the proof of closure switch can be removed.

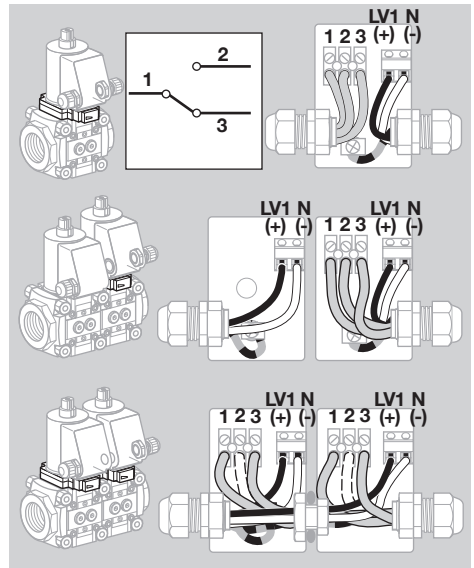

LV1_{V1} (+) = black, N (-) = blue

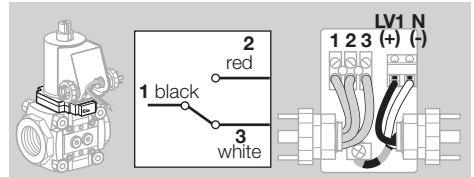

- ▷ Label the plugs to avoid confusion.
- 1 = N (-), 2 = LV1_{V1} (+)

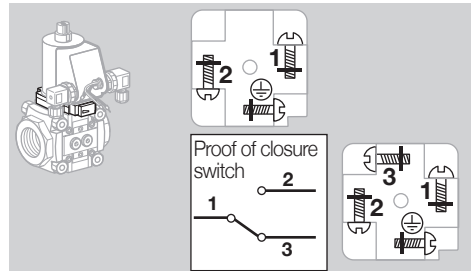

- ▷ Ensure that the connection terminal for the proof of closure switch has been reconnected.

Finishing the wiring

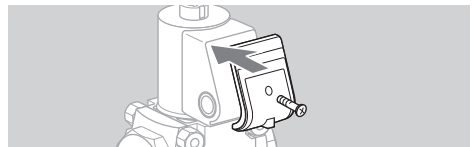

Tightness test

- 1 Close the gas solenoid valve.
- 2 To be able to check the tightness, shut off the downstream pipeline close to the valve.

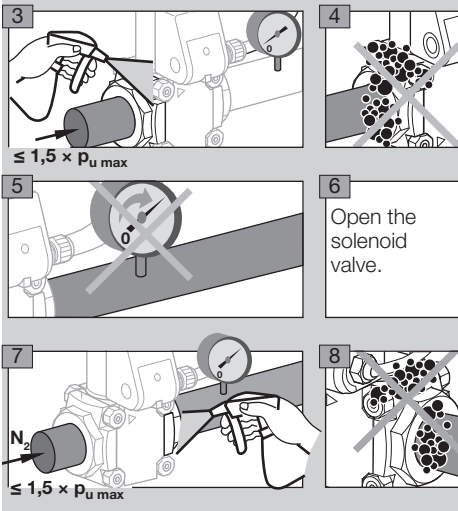

- 9 Tightness OK: open the pipeline.
- ▷ Pipeline leaking: replace O-ring on flange, see page 13 (Seal set for sizes 1–3). Then check for tightness once again.
 - ▷ Unit leaking: remove the unit and return it to the manufacturer.

Commissioning

Setting the flow rate

- ▷ At the factory, the gas solenoid valve is adjusted for maximum flow rate Q.
- ▷ The markings on the cover cap can be used for coarse adjustment of the flow rate.
- ▷ The cover cap can be rotated without changing the current flow rate.
- ▷ Allen key: 2.5 mm.
- ▷ Do not turn beyond the “max.” setting.

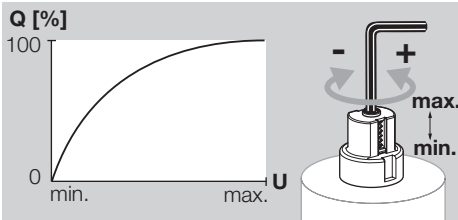

- ▷ The VAS remains tight even if the adjusting screw is overturned.

Setting the start gas rate on VAS../L, VCS..L

- ▷ The start gas rate can be set by turning the damping unit a maximum of 5 turns.
- ▷ There must be a period of 20 seconds between switching the valve off and on again so that the damping is fully effective.
- ▷ Loosen the M5 setscrew (2.5 mm hexagon socket), but do not unscrew completely.

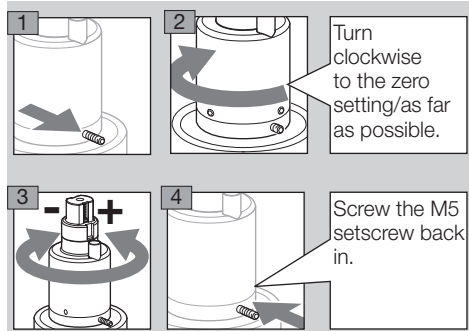

Setting the damping speed

- ▷ The opening speed can be influenced by turning the nozzle screw on the damping unit.

! CAUTION

Attention! To avoid leakage, please observe the following:

- If the nozzle screw is turned by more than 1 turn, the damping unit will leak and will have to be replaced.
- ▷ Turn the nozzle screw a maximum of ½ a turn in the appropriate direction.

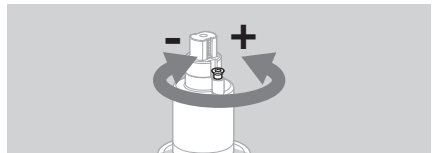

Replacing the actuator

- ▷ The actuator adapter set is enclosed with new actuators.

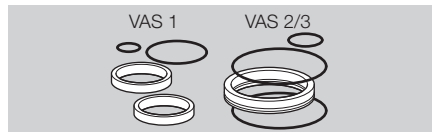

- ▷ The seals of the actuator adapter set are covered with a non-stick coating. No additional grease is required.

VAS without damping

- 1 Disconnect the system from the electrical power supply.
 - 2 Shut off the gas supply.
- ▷ Remove the M20 cable gland or other type of connection.



- ▷ Depending on the construction stage of the unit, there are two different methods for replacing the actuator:
If the unit concerned has no O-ring in this place (arrow), replace the actuator as described here. Otherwise, go to the next note.

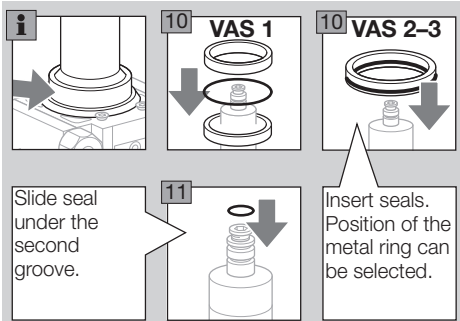

- ▷ If the unit concerned has an O-ring in this place (arrow), replace the actuator as described here:
▷ VAS 1: use all seals from the actuator adapter set.
▷ VAS 2/3: use the small seal from the actuator adapter set and only one of the large seals.

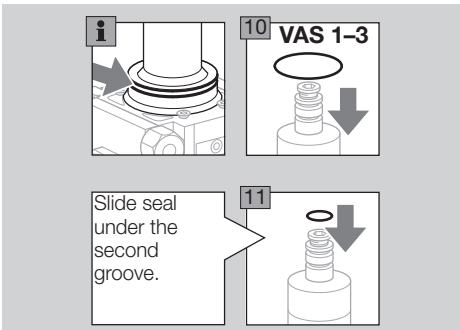

12 Position new actuator.

- 13** Follow the reverse procedure when reassembling.
14 Fit the M20 cable gland or plug and socket.
15 Connect the VAS to the electrical power supply, see page 4 (Wiring).

VAS../L with damping unit

- 1** Disconnect the system from the electrical power supply.
2 Shut off the gas supply.
▷ Loosen the setscrews, but do not unscrew completely (M3 = 1.5 mm hexagon socket, M5 = 2.5 mm hexagon socket).

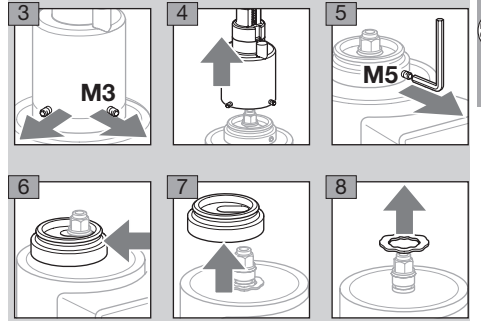

- 9** For further disassembly and replacing the actuator, see page 6 (Replacing the actuator).
▷ Once the new actuator has been wired, the damping unit can be fitted as described below and set to the desired start gas rate.

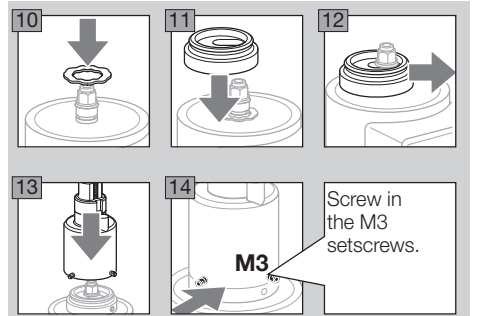

- 15** Open the gas solenoid valve and the gas supply.
16 Set the start gas rate, see page 6 (Setting the start gas rate on VAS../L, VCS../L). The connection between solenoid actuator and damping unit must then be checked for tightness.

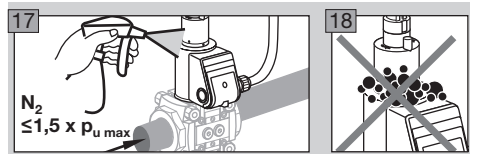

Replacing the damping unit

- 1 Disconnect the system from the electrical power supply.
- 2 Shut off the gas supply.
 - ▷ Loosen the M3 setscrews (1.5 mm hexagon socket), but do not unscrew completely.

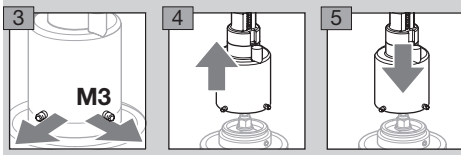

- 6 Screw the M3 setscrews back in again.
- 7 Open the solenoid valve and the gas supply.
- 8 Set the start gas rate, see page 6 (Setting the start gas rate on VAS../L, VCS../L). The connection between solenoid actuator and damping unit must then be checked for tightness.

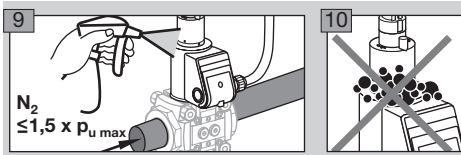

Maintenance

! CAUTION

In order to ensure smooth operation, check the tightness and function of the VAS:

- Once per year, twice per year in the case of biogas; check for internal and external tightness, see page 6 (Tightness test).
 - Check electrical installations once a year in line with local regulations; pay particular attention to the PE wire, see page 4 (Wiring).
- ▷ If the flow rate has dropped, clean the strainer.
- ▷ If more than one valVario control is installed in series: the controls may only be removed from the pipeline and reinstalled on the inlet and outlet flange all at once.
- ▷ We recommend replacing the seals, see page 13 (Seal set for sizes 1–3).

- 1 Disconnect the system from the electrical power supply.
- 2 Shut off the gas supply.
- 3 Undo connection parts.

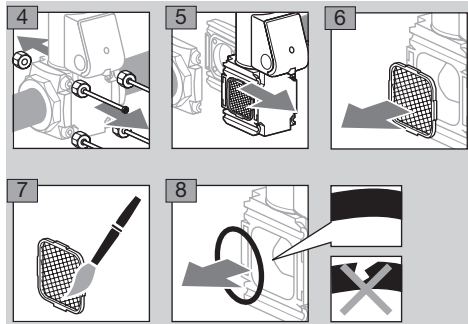

- 9 Once the seals have been replaced, follow the reverse procedure to reassemble the unit.
- 10 Then check the unit for internal and external tightness, see page 6 (Tightness test).

Accessories

Pressure switch for gas DG..VC

- ▷ The pressure switch for gas monitors the inlet pressure p_u , the outlet pressure p_d and the interspace pressure p_z .

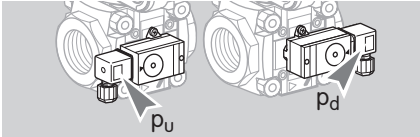

- ▷ When using two pressure switches on the same side of the double solenoid valve, only the combination DG..C..1 and DG..C..9 may be used for design reasons.

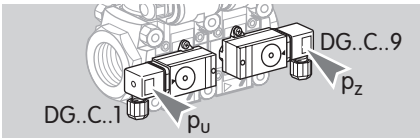

- ▷ When retrofitting the pressure switch for gas, see enclosed operating instructions "Pressure switches for gas DG..C", section entitled "Mounting the DG..C..1, DG..C..9 on valVario gas solenoid valves".
- ▷ The switching point is adjustable via hand wheel.

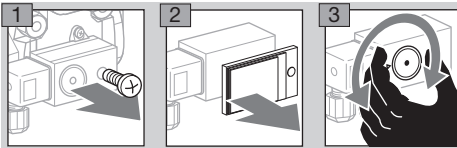

	Adjusting range (adjusting tolerance = ± 15% of the scale value)		Mean switching differential at min. and max. setting	
	[mbar]	["WC]	[mbar]	["WC]
DG 17VC	2–17	0.8–6.8	0.7–1.7	0.3–0.8
DG 40VC	5–40	2–16	1–2	0.4–1
DG 110VC	30–110	12–44	3–8	0.8–3.2
DG 300VC	100–300	40–120	6–15	2.4–8

- ▷ Deviation from the switching point during testing pursuant to EN 1854 Gas pressure switches: ± 15%.

Bypass/pilot gas valves

- 1 Disconnect the system from the electrical power supply.
 - 2 Shut off the gas supply.
 - 3 Prepare the installed main valve.
- ▷ Turn the actuator so that the side on which the bypass/pilot gas valve is to be installed is accessible.

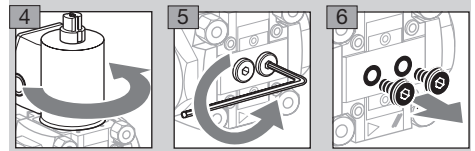

VBV for VAS 1

Scope of delivery

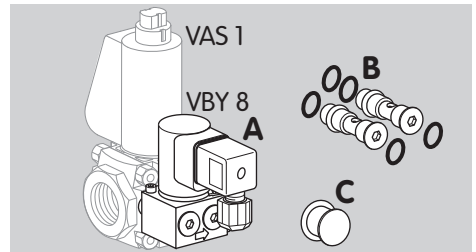

Bypass valve VBY..I

- A** 1 x bypass valve VBY..I
- B** 2 x retaining screws with 4 x O-rings: both retaining screws have a bypass orifice
- C** Grease for O-rings
- ▷ The screw plug at the outlet remains in place.

Pilot gas valve VBY..R

- A** 1 x pilot gas valve VBY..R
- B** 2 x retaining screws with 5 x O-rings: one retaining screw has a bypass orifice (2 x O-rings), the other does not (3 x O-rings)
- C** Grease for O-rings
- ▷ Remove the screw plug at the outlet and connect the Rp ¼ pilot gas line.

Mounting the VBY

- 7 Grease O-rings **B**.

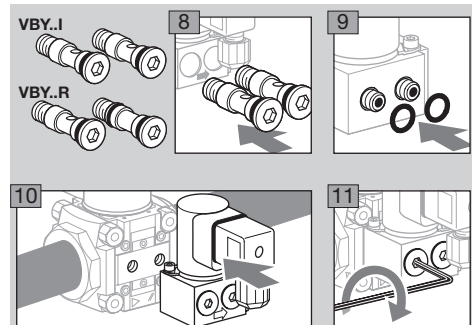

- ▷ Tighten the retaining screws alternately so that VBY and VAS are flush.

Setting the flow rate

- ▷ The flow rate can be set by turning the flow rate restrictor (4 mm hexagon socket) $\frac{1}{4}$ of a turn.

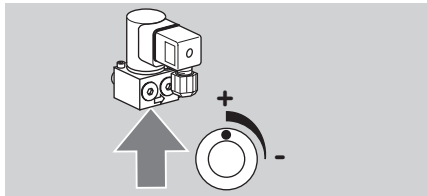

- ▷ Only adjust the flow rate restrictor in the marked range, otherwise the required gas volume will not be reached.

12 Wire the socket, see page 4 (Wiring).

13 Check for tightness, see page 11 (Checking the bypass/pilot gas valve for tightness).

VAS 1 for VAS 1, VAS 2, VAS 3

Scope of delivery

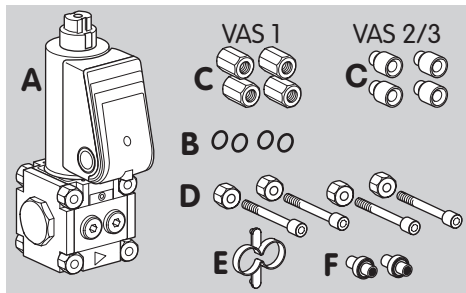

A 1 x bypass/pilot gas valve VAS 1

B 4 x O-rings

C 4 x double nuts for mounting to VAS 1

or

4 x spacer sleeves for mounting to VAS 2/3

D 4 x connection parts

E 1 x mounting aid

Bypass valve VAS 1

F 2 x connection pipes, if the bypass valve has a blind flange on the outlet side

Pilot gas valve VAS 1

F 1 x connection pipe, 1 x sealing plug, if the pilot gas valve has a threaded flange on the outlet side

Mounting the bypass/pilot gas valve VAS 1

- ▷ Always use a connection pipe **F** at the inlet of the main valve.

- ▷ For a bypass valve: use connection pipe **F** \varnothing 10 mm (0.39") at the outlet of the main valve if the bypass valve's outlet flange is designed as a blind flange.

- ▷ For the pilot gas valve: insert sealing plug **F** at the outlet of the main valve if the pilot gas valve's outlet flange is designed as a threaded flange.

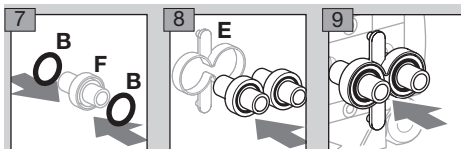

10 Remove the sealing plugs on the mounting side of the bypass valve.

VAS 1 to VAS 1

11 Remove the nuts from the connection parts on the mounting side of the main valve.

12 Remove the connection parts of the bypass/pilot gas valve.

- ▷ Use the new connection parts **C** and **D** from the scope of delivery for the bypass/pilot gas valve.

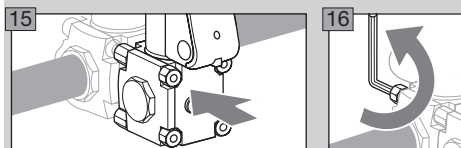
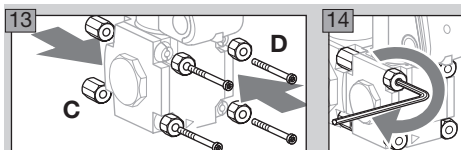

17 Wire the bypass/pilot gas valve VAS 1, see page 4 (Wiring).

18 Check for tightness, see page 11 (Checking the bypass/pilot gas valve for tightness).

VAS 1 for VAS 2 or VAS 3

- ▷ The connection parts of the main valve remain mounted.

11 Remove the connection parts of the bypass/pilot gas valve.

- ▷ Use the new connection parts **C** and **D** from the scope of delivery for the bypass/pilot gas valve. For VAS 2 and VAS 3, the connection parts consist of self-tapping screws.

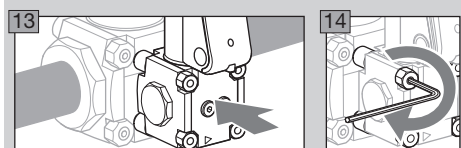
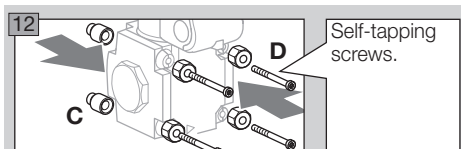

15 Wire the bypass/pilot gas valve VAS 1, see page 4 (Wiring).

16 Check for tightness, see page 11 (Checking the bypass/pilot gas valve for tightness).

Checking the bypass/pilot gas valve for tightness

1 To be able to check the tightness, shut off the downstream pipeline as close as possible to the valve.

2 Close the main valve.

3 Close the bypass/pilot gas valve.

! CAUTION

If the actuator of the VBY is rotated, the tightness can no longer be guaranteed. To ensure that there are no leaks, check the actuator of the VBY for tightness.

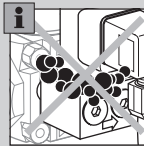
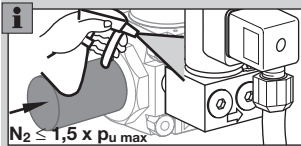

Check the bypass/pilot gas valve for tightness at the inlet and outlet.

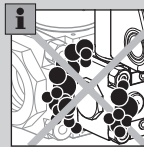
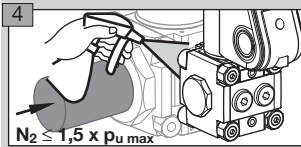

5 Open the bypass or pilot gas valve.

Bypass valve

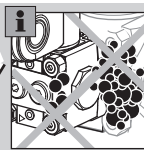
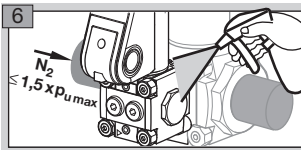

Pilot gas valve

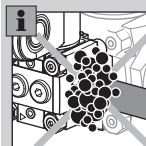
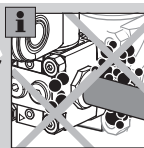
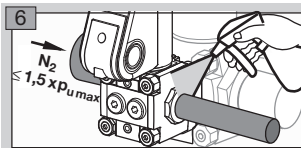

Tightness control TC 1V

- 1** Disconnect the system from the electrical power supply.
- 2** Shut off the gas supply.
 - ▷ The solenoid actuator cannot be rotated on solenoid valves with proof of closure switch VCx..S or VCx..G.
 - ▷ Connect the TC to the inlet pressure connection p_u and the interspace pressure connection p_z of the inlet valve. Ensure that connections p_u and p_z on the TC and the gas solenoid valve are not reversed.
 - ▷ TC and bypass/pilot gas valve cannot be fitted together on the same side of the double block valve.
 - ▷ When using a valve/pressure regulator combination VCG/VCV/VCH, the pressure regulator must be activated with air during the entire test period t_p .
 - ▷ The TC is secured using two captive combination Torx screws T20 (M4) inside the housing. Do not undo any other screws!

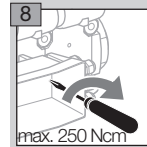
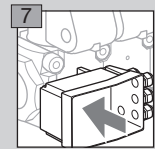
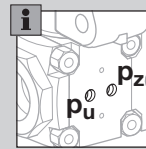
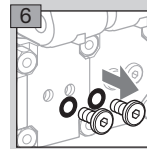
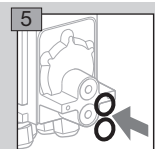
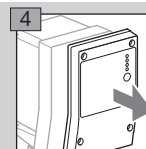
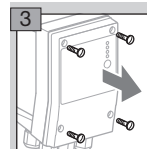
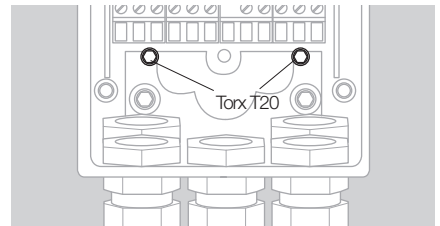

- ▷ For more information on wiring, testing the tightness and commissioning, see enclosed "Tightness control TC 1, TC 2, TC 3" operating instructions.
- 9** After completing the wiring, tightness test and commissioning for the TC, refit the housing cover on the TC.

Cable gland set for double solenoid valves

- ▷ When wiring a double solenoid valve, the connection boxes are to be connected using a cable gland set.

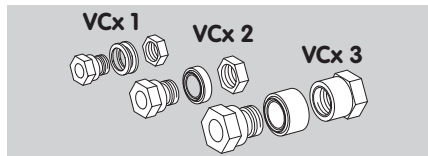

- ▷ Order No. for size 1: 74921985, size 2: 74921986, size 3: 74921987.
- ▷ We recommend preparing the connection boxes before the double solenoid valve is installed in the pipework. Alternatively, one of the actuators must be dismantled as described below and reinstalled rotated by 90° in preparation for installation of the double solenoid valve.
- ▷ The cable gland set can only be used if the connection boxes are at the same height and on the same side.

- 1 Disconnect the system from the electrical power supply.
- 2 Shut off the gas supply.

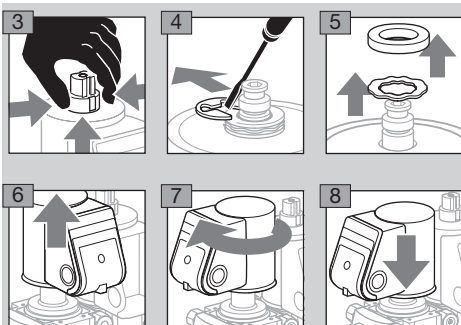

- ▷ In both connection boxes, push through the knock-out for the cable gland set – then remove the covers. The covers must not be taken off before pushing through the knock-outs as it prevents damage to the connection boxes.

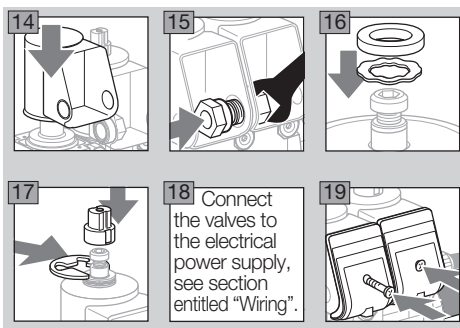
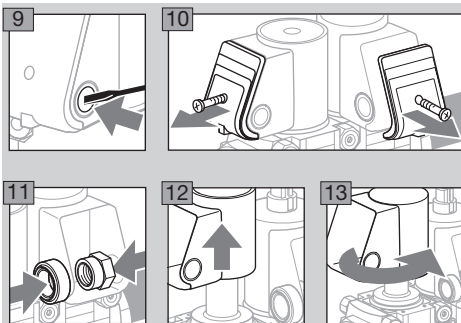

Attachment block

- ▷ For locked installation of pressure gauge or other accessories, the attachment block is mounted to the solenoid valve.

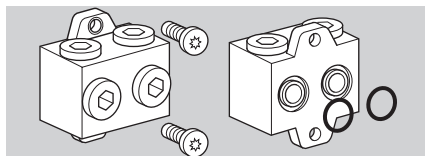

- ▷ Order No. 74922228

 - 1 Disconnect the system from the electrical power supply.
 - 2 Shut off the gas supply.

 - ▷ Use the enclosed self-tapping screws for installation.

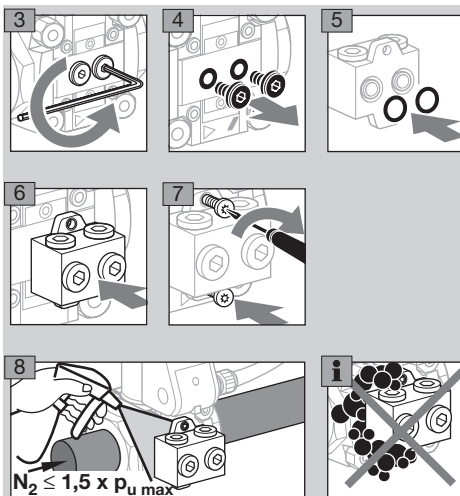

- 9 Shut off the downstream gas pipeline close to the solenoid valve.
- 10 Open the solenoid valve.

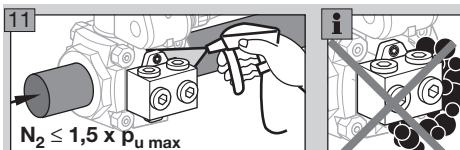

Seal set for sizes 1–3

- ▷ When retrofitting accessories or a second valVario control or when servicing, we recommend replacing the seals.

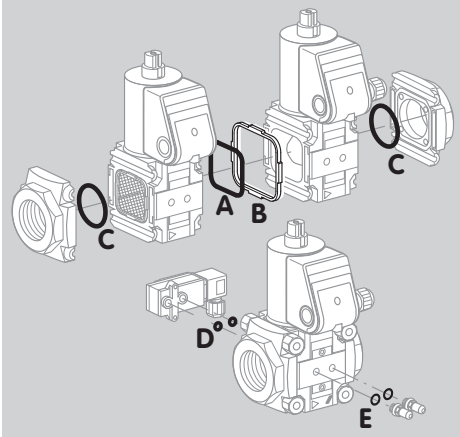

- ▷ Order No. for size 1: Order No. 74921988, size 2: Order No. 74921989, size 3: Order No. 74921990.
- ▷ Scope of delivery:
 - A** 1 x double block seal,
 - B** 1 x retaining frame,
 - C** 2 x O-rings (flange),
 - D** 2 x O-rings (pressure switch), for pressure test point/screw plug:
 - E** 2 x sealing rings (flat sealing), 2 x profiled sealing rings.

Cable gland with pressure equalization element

- ▷ To avoid the formation of condensation, the cable gland with pressure equalization element can be used instead of the standard M20 cable gland. The diaphragm in the gland is designed to ventilate the device, without allowing water to enter.
- ▷ 1 x cable gland, Order No.: 74924686

Technical data

Gas types: natural gas, LPG (gaseous), biogas (max. 0.1 %-by-vol. H₂S) or clean air; other types of gas on request.

The gas must be clean and dry in all temperature conditions and must not contain condensate.

Max. inlet pressure p_U :

max. 500 mbar (7.25 psig).

FM approved, non operational pressure:

700 mbar (10 psig).

ANSI/CSA approved:

350 mbar (5 psig).

The flow adjustment facility limits the maximum flow rate:

VAS: 20 to 100%,

VBV: 10 to 100%.

The setting can be monitored on an indicator.

VAS../L: start gas rate adjustment:

0 to 70%.

Opening times:

VAS../N quick opening: ≤ 1 s,

VAS../L slow opening: up to 10 s.

Closing time: quick closing: < 1 s.

Medium and ambient temperatures:

VAS: -20 to +60°C (-4 to +140°F),

VBV: 0 to +60°C (32 to 140°F).

No condensation permitted.

Long-term use in the upper ambient temperature range accelerates the ageing of the elastomer materials and reduces the service life (please contact manufacturer).

Storage temperature: -20 to +40°C (-4 to +104°F).

Enclosure: VAS: IP 65, VBV: IP 54.

Valve housing: aluminium, valve seal: NBR.

Connection flanges with internal thread:

Rp to ISO 7-1, NPT to ANSI/ASME.

Class A, Group 2 safety valve pursuant to

EN 13611 and EN 161, 230 V AC, 120 V AC,

24 V DC:

Factory Mutual (FM) Research Class:

7400 and 7411, ANSI Z21.21 and CSA 6.5.

Mains voltage:

230 V AC, +10/-15%, 50/60 Hz;

200 V AC, +10/-15%, 50/60 Hz;

120 V AC, +10/-15%, 50/60 Hz;

100 V AC, +10/-15%, 50/60 Hz;

24 V DC, $\pm 20\%$.

Cable gland: M20 x 1.5.

Electrical connection:

electrical cable with max. 2.5 mm² (AWG 12) or plug with socket to EN 175301-803.

Power consumption:

Type	Voltage	Power
VAS 1	24 V DC	25 W –
	100 V AC	25 W (26 VA)
	120 V AC	25 W (26 VA)
	200 V AC	25 W (26 VA)
	230 V AC	25 W (26 VA)
VAS 2, VAS 3	24 V DC	36 W –
	100 V AC	36 W (40 VA)
	120 V AC	40 W (44 VA)
	200 V AC	40 W (44 VA)
VBY	230 V AC	40 W (44 VA)
	24 V DC	8 W –
	120 V AC	8 W –
	230 V AC	9.5 W –

Switching frequency:

VAS../N: max. 30 x per minute,

VAS../L: there must be a period of 20 seconds between switching off and on again so that the damping is fully effective.

Duty cycle: 100%.

Power factor of the solenoid coil: $\cos \phi = 0.9$.

Contact rating of proof of closure switch:

Type	Voltage	Min. current (resistive load)	Max. current (resistive load)
VAS..S	12–250 V AC, 50/60 Hz	100 mA	3 A
VAS..G	12–30 V DC	2 mA	0.1 A

Switching frequency of proof of closure switch:

max. 5 x per minute.

Switching current [A]	Switching cycles*	
	$\cos \phi = 1$	$\cos \phi = 0.6$
0.1	500,000	500,000
0.5	300,000	250,000
1	200,000	100,000
3	100,000	–

* Limited to max. 200,000 cycles for heating systems.

Air flow rate Q

Air flow rate Q for a pressure loss of $\Delta p = 1$ mbar (0.4 "WC)

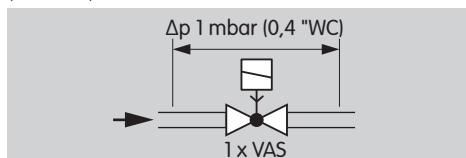

Type	Air flow rate	
	Q [m³/h]	Q [SCFH]
VAS 110	4.4	155.4
VAS 115	5.6	197.7
VAS 120	8.4	296.6
VAS 125	9.5	335.5
VAS 225	16.7	589.7
VAS 232	21	741.5
VAS 240	23.2	819.2
VAS 250	23.7	836.8
VAS 340	33.6	1186.4
VAS 350	36.4	1285.3
VAS 365	37.9	1338.2

Air flow rate Q for a pressure loss of $\Delta p = 10$ mbar 4 "WC)

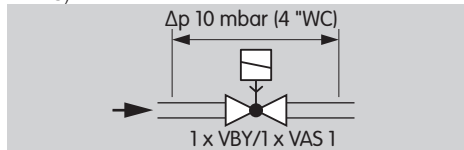

Type	Air flow rate	
	Q [m³/h]	Q [SCFH]
Bypass valve VBY	0.85	30.01
Pilot gas valve VBY	0.89	31.43

Type	Ø [mm]	Air flow rate	
		Q [m³/h]	Q [SCFH]
Bypass valve VAS 1	1	0.2	0.04
	2	0.5	0.08
	3	0.8	0.12
	4	1.5	0.16
	5	2.3	0.20
	6	3.1	0.24
	7	3.9	0.28
	8	5.1	0.31
	9	6.2	0.35
	10	7.2	0.39
Pilot gas valve VAS 1	10	8.4	0.39

Designed lifetime

This information on the designed lifetime is based on using the product in accordance with these operating instructions. Once the designed lifetime has been reached, safety-relevant products must be replaced. Designed lifetime (based on date of manufacture) in accordance with EN 13611, EN 161 for VAS:

Type	Designed lifetime	
	Switching cycles	Time [years]
VAS 110 – VAS 225	500,000	10
VAS 232 – VAS 365	200,000	10

You can find further explanations in the applicable rules and regulations and on the afecor website (www.afecor.org).

This procedure applies to heating systems. For thermoprocessing equipment, observe local regulations.

Transport

Protect the unit from external forces (blows, shocks, vibration). On receipt of the product, check that the delivery is complete, see page 2 (Part designations). Report any transport damage immediately.

Storage

Store the product in a dry and clean place.
Storage temperature: see page 13 (Technical data).
Storage time: 6 months before using for the first time. If stored for longer than this, the overall service life will be reduced by the corresponding amount of extra storage time.

Packaging

The packaging material is to be disposed of in accordance with local regulations.

Disposal

Components are to be disposed of separately in accordance with local regulations.

Declaration of conformity



We, the manufacturer, hereby declare that the products VAS, marked with product ID No. CE-0063BO1580, comply with the essential requirements of the following Directives and Standards:

Directives:

- 2009/142/EC – GAD (valid until 20 April 2018)
- 2014/35/EU – LVD
- 2014/30/EU – EMC

Regulation:

- (EU) 2016/426 – GAR (valid from 21 April 2018)

Standards:

- EN 161
- EN 88
- EN 126
- EN 1854

The relevant product corresponds to the type tested by the notified body 0063.

The production is subject to the surveillance procedure pursuant to Directive 2009/142/EC Annex II paragraph 3 (valid until 20 April 2018) and to Regulation (EU) 2016/426 Annex III paragraph 3 (valid from 21 April 2018).

Elster GmbH

Scan of the Declaration of conformity (D, GB) – see www.docuthek.com

SIL, PL

The solenoid valves VAS 1–3 are suitable for single-channel systems (HFT = 0) up to SIL 2/PL d, and up to SIL 3/PL e when two redundant solenoid valves are installed in a double-channel architecture (HFT = 1), provided that the complete system complies with the requirements of EN 61508/ISO 13849. The safety function value which is actually achieved is derived by taking all components into account (sensor – logic – actuator). For this, the demand rate and structural measures to avoid/detect nonconformity are to be observed (e.g. redundancy, diversity, monitoring).

Characteristic values for SIL/PL: HFT = 0 (1 device), HFT = 1 (2 devices), SFF > 90, DC = 0, type A/category B, 1, 2, 3, 4, high demand mode, CCF > 65, β ≥ 2.

$$PFH_D = \lambda_D = \frac{1}{MTTF_d} = \frac{0.1}{B_{10d}} \times n_{op}$$

VAS	B _{10d} value
Size 1	15,845,898
Sizes 2 – 3	15,766,605

FM approved*



Factory Mutual (FM) Research Class:
7400 and 7411 Safety overpressure slam shut valves.
Designed for applications pursuant to NFPA 85 and
NFPA 86.

ANSI/CSA approved*



Canadian Standards Association –
ANSI Z21.21 and CSA 6.5

UL listed*



Underwriters Laboratories – UL 429
“Electrically operated valves”.

AGA approved*



Australian Gas Association

Eurasian Customs Union



The product VAS, VCS meets the technical specifica-
tions of the Eurasian Customs Union.

Directive on the restriction of the use of hazardous substances (RoHS) in China

Scan of the Disclosure Table China RoHS2 – see
certificates at www.docuthek.com

* Approval does not apply for 100 V AC or 200 V AC.

Contact

If you have any technical questions, please contact
your local branch office/agent. The addresses are
available on the Internet or from Elster GmbH.

We reserve the right to make technical modifications
in the interests of progress.

Honeywell

**krom//
schroder**

Elster GmbH
Strotheweg 1, D-49504 Lotte (Büren)
Tel. +49 541 1214-0

Fax +49 541 1214-370

hts.lotte@honeywell.com, www.kromschroeder.com